

THERMAL PRINTER

TSP400Z SERIES

***USER'S MANUAL
MODE D'EMPLOI
BEDIENUNGSANLEITUNG
MANUALE DI ISTRUZIONI***

stair 

**Federal Communications Commission
Radio Frequency Interference
Statement**

This device complies with Part 15 of the FCC Rules. Operation is subject to the following two conditions: (1) This device may not cause harmful interference, and (2) this device must accept any interference received, including interference that may cause undesired operation.

NOTE: This equipment has been tested and found to comply with the limits for a Class A digital device, pursuant to Part 15 of the FCC Rules. These limits are designed to provide reasonable protection against harmful interference when the equipment is operated in a commercial environment. This equipment generates, uses and can radiate radio frequency energy and, if not installed and used in accordance with the instruction manual, may cause harmful interference to radio communications. Operation of this equipment in a residential area is likely to cause harmful interference in which case the user will be required to correct the interference at his own expense.

This statement will be applied only for the printers marketed in U.S.A.

FCC WARNING

Changes or modifications not expressly approved by the party responsible for compliance could void the user's authority to operate the equipment.

For compliance with the Federal Noise Interference Standard, this equipment requires a shielded cable. For RF interference suppression, if a ferrite core is provided with this device, affix it to the interface cable.

**Statement of
The Canadian Department of Communications
Radio Interference Regulations**

This Class A digital apparatus complies with Canadian ICES-003.

Cet appareil numérique de la classe A est conforme à la norme NMB-003 du Canada.

The above statement applies only to printers marketed in Canada.

Trademark acknowledgments

TSP400Z, TSP400: *Star Micronics Co. Ltd.*

Notice

- All rights reserved. Reproduction of any part of this manual in any form whatsoever, without STAR's express permission is forbidden.
- The contents of this manual are subject to change without notice.
- All efforts have been made to ensure the accuracy of the contents of this manual at the time of going to press. However, should any errors be detected, STAR would greatly appreciate being informed of them.
- The above notwithstanding, STAR can assume no responsibility for any errors in this manual.

TABLE OF CONTENTS

1. UNPACKING AND INSPECTION	1
1-1. Unpacking	1
1-2. Handling Notes	1
2. PARTS IDENTIFICATION AND NOMENCLATURE	2
3. FERRITE CORE INSTALLATION *EUROPE ONLY	3
3-1. Parallel interface	3
3-2. Peripheral unit cable	4
4. CONNECTING THE INTERFACE CABLE	5
4-1. Serial interface	5
4-2. Parallel interface	5
5. SETTING UP	6
5-1. Loading the Paper Roll	6
5-2. Adjusting the Head Position	8
6. CONTROL PANEL	9
6-1. Basic Operation	9
6-2. Power switch and ON LINE/FEED switch combinations	10
6-3. Print Density Adjustment	12
6-4. Sensor Adjustment Mode	12
6-5. Errors	14
6-6. Buzzer Sounding Variations	15
APPENDIX A: SPECIFICATIONS	64
A-1. General Specifications	64
A-2. Paper Specifications	65
APPENDIX B: DIP SWITCH SETTING	68
B-1. Serial Interface	69
B-2. Parallel Interface	69
APPENDIX C: SERIAL INTERFACE	70
C-1. Connectors and Signal Names (Serial Interface)	70
C-2. Interface Connections	71
APPENDIX D: PARALLEL INTERFACE	72
D-1. Table of Connection Signals for Each Mode	72
APPENDIX E: PERIPHERAL UNIT DRIVE CIRCUIT	74
APPENDIX F: MEMORY SWITCH SETTINGS	76

1. Unpacking and inspection

1-1. Unpacking

Check each item in the box against Fig. 1-1 to make sure that you have everything. If any of these items are missing, contact your supplier.

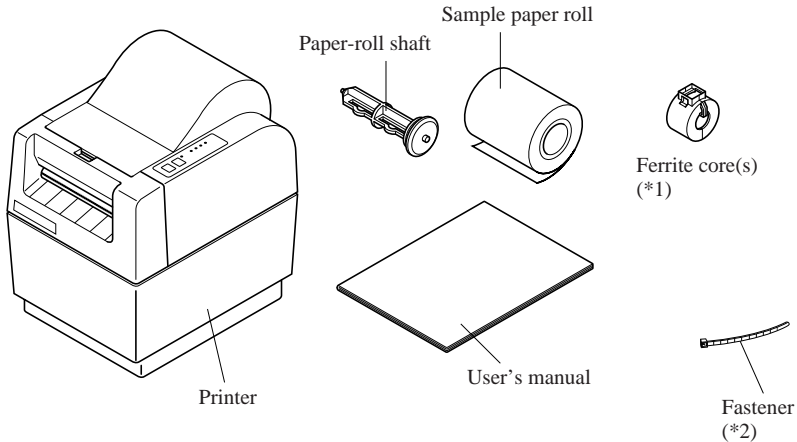

*1 The Ferrite core is included only with printers marketed in Europe.

Two are parallel interface models and one is serial interface model.

*2 A fastener is included only with printers marketed in Europe.

Fig. 1-1

1-2. Handling Notes

Before you start setting up your printer, make sure that you have a suitable place in which to locate it. By “a suitable place”, we mean:

- Close to an easily accessible socket-outlet.
- A firm, level surface which is fairly vibration-free.
- Away from excessive heat (such as direct sunlight, heaters, etc).
- Away from excessive humidity.
- Away from excessive dust.
- With access to a steady power supply that is not subject to power surges. For example, do not connect the printer to the same circuit as a large, noise-producing appliance such as a refrigerator or an air conditioner.

NOTE: Make sure that the line voltage is the voltage specified on the printer's identification plate.

2. Parts identification and nomenclature

To get acquainted with the printer's components and capabilities, refer to Fig. 2-1.

Printer cover

Protects the print head and other internal components of your printer.

Control panel

Indicates printer status and makes control of printer functions simple and convenient.

Automatic paper cutter

(Controlled by command)

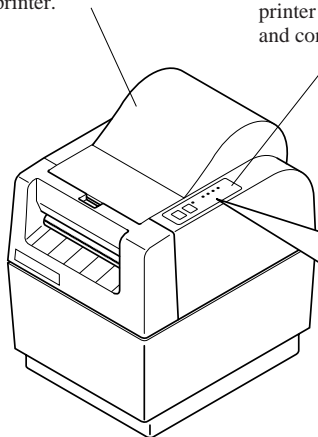

(TSP412Z)

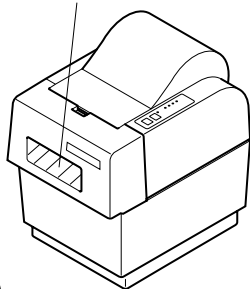
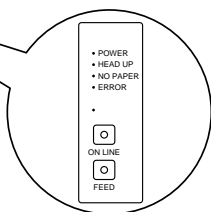

(TSP442Z)

Release bar

Opens and closes the print head unit which holds the paper against the platen.

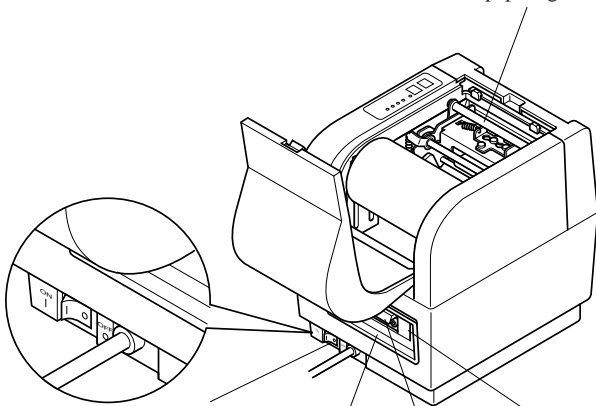

Power switch

Switches power on or off.

Connector cover

Interface connector

Connects the computer to the printer.

Peripheral drive connector

Only connects to peripheral units such as each drawer etc.
Do not connect this to a telephone.

Fig. 2-1

3. Ferrite core installation *Europe only

NOTE: Take special care when following the procedures listed below.

3-1. Parallel interface

- Ferrite core is packed so it is open, as shown in Fig. 3-2. If you find that a ferrite core is not open, use a pointed object to pry the plastic lock of the ferrite core apart (Fig. 3-1). When you do this, take care not to damage the ferrite core or the plastic lock.

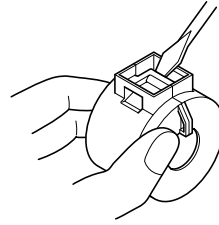

Fig. 3-1

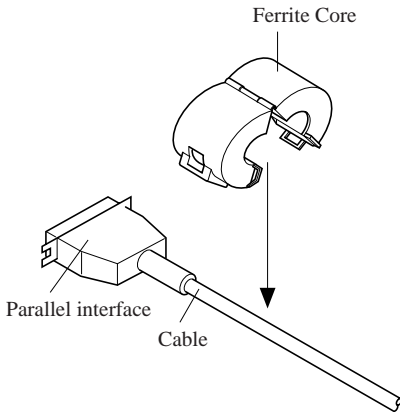
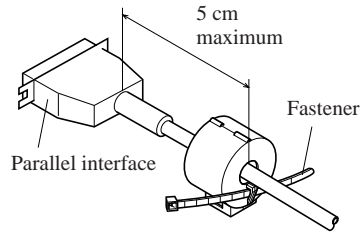
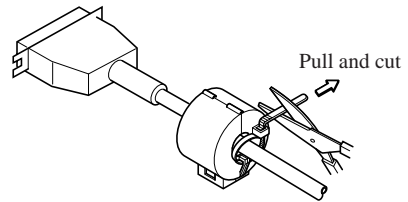

Fig. 3-2



Pass fastener through ferrite core.

Fig. 3-3



Pass fastener around cable and lock it.
Cut off excess with scissors.

Fig. 3-4

- Clamp the ferrite core onto the interface cable as shown in Fig. 3-2. Take care to avoid damaging the interface cable when installing the ferrite core. The ferrite core should be anchored firmly in place with the fastener that comes with it, as shown in Fig.3-3 and 3-4.

3-2. Peripheral unit cable

■ Clamp the ferrite core onto the cable of the peripheral unit using the same procedure as you do for the parallel interface cable ferrite core. With the peripheral unit cable ferrite core, however, you have to loop the cable as shown in Fig. 3-5.

NOTE: The ferrite cores only need to be attached for the European region (only printers marketed in Europe are eligible.)
Install both the parallel interface model and the serial interface model.

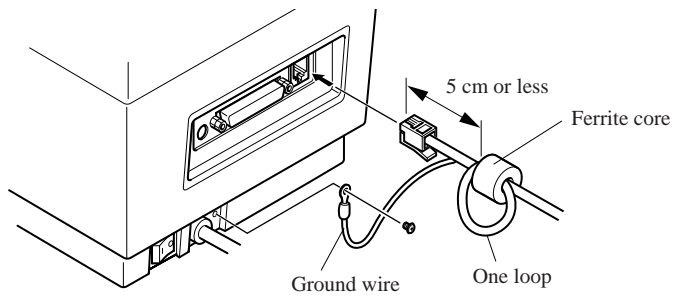
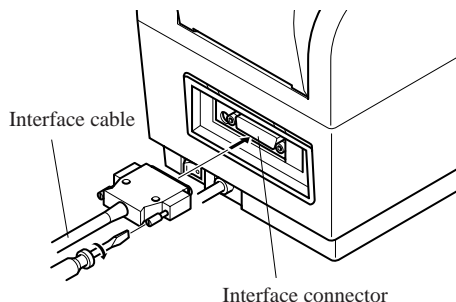

Fig. 3-5

4. Connecting the interface cable

4-1. Serial interface

Follow the procedures below to connect the interface cable:



- ① Switch off the power to the printer and computer.
- ② Insert the interface cable in the connector. (Be sure that the cable is oriented correctly before inserting it.)
- ③ Fasten the right and left screws to fix them in place on the connector.
- ④ Connect the other end of the interface cable to your computer.

Fig. 4-1

NOTE: The data transfer conditions between the computer and the printer must be made compatible with the DIP switch settings on the printer. (Refer to “APPENDIX”.)

4-2. Parallel interface

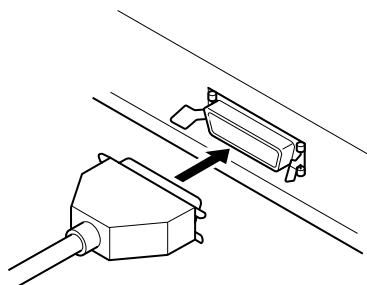

- ① Switch off the power to the printer and computer.
- ② Insert the interface cable in the connector. (Be sure that the cable is oriented correctly before inserting it.)
- ③ Fasten the connector clasps.
- ④ Connect the other end of the interface cable to your computer.

Fig. 4-2

5. Setting up

- First, remove the blue semi-transparent tape from all parts.
- Before loading the first paper roll, be sure to remove the cardboard and the protective paper (under the tear bar) that were inserted to protect the print head during shipping.

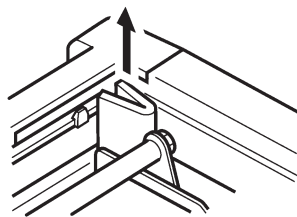

Fig. 5-1

5-1. Loading the Paper Roll

The procedure for loading a paper roll is as follows. The illustrations show the TSP412Z printer. However, the loading procedure for the TSP442Z is the same.

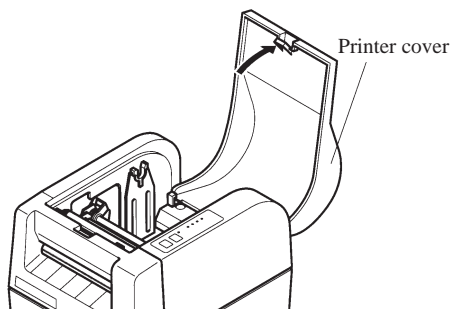

Fig. 5-2

- ① Switch off the printer's power.
- ② Open the printer cover.

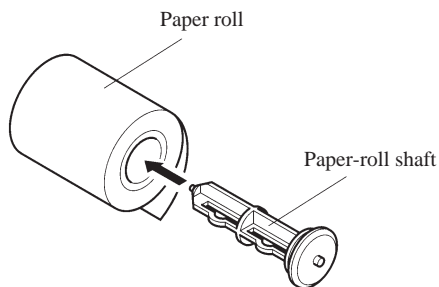

Fig. 5-3

- ③ Cut the top edge of the paper straight across. If the paper end is secured to the roll by a label or by tape, unroll the paper one turn and cut away all traces of adhesive. (Adhesive can stick to the internal paper roller and interfere with paper feeding.)
- ④ Insert the paper-roll shaft into the paper roll.

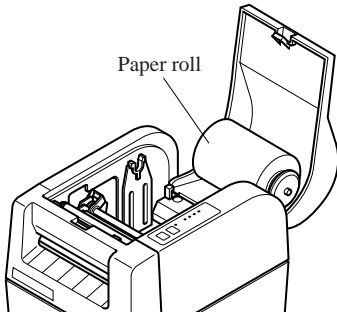

Fig. 5-4

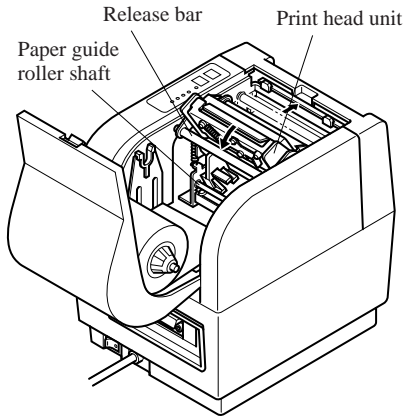

Fig. 5-5

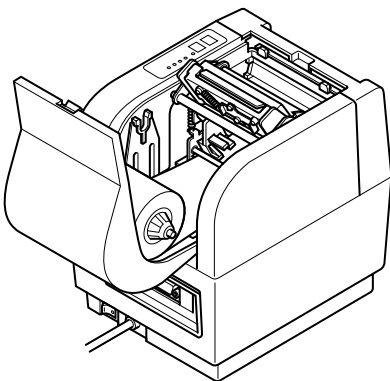

Fig. 5-6

⑤ Temporarily place the paper roll on the printer cover. Be sure that the roll is correctly oriented for loading.

⑥ Pull on the green release bar so that it unlocks, then tilt the print head unit. Avoid touching the print head with your fingers.

⑦ Insert the paper so that it passes under the paper-guide roller shaft and between the transmissive sensors.

⑧ Push the paper until the edge moves all the way through to the tear bar.

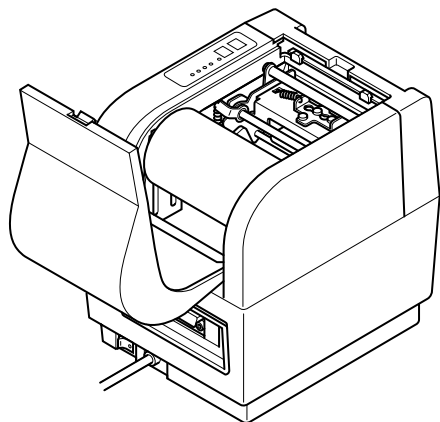

Fig. 5-7

- ⑨ Return the print head unit to its original position and be sure that it locks into place. (The printer cover will not close unless the print head unit is locked.)
- ⑩ Move the paper roll onto the printer's paper-roll holder.
- ⑪ Hold the roll down and pull on the leading edge of the paper to remove any slack.
- ⑫ Close the printer cover.

5-2. Adjusting the Head Position

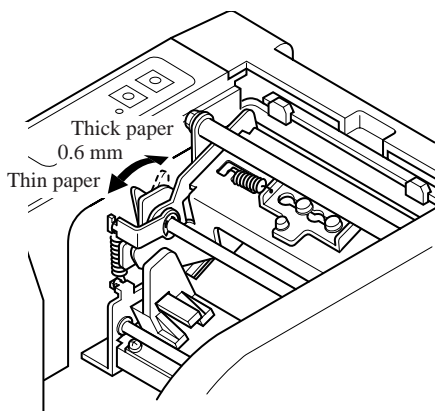

Fig. 5-8

- ① You can set the print head position to accommodate thick or thin paper. Change the position by moving the left-side and right-side levers forward or back.
- ② Be sure to unlock the print head before moving the levers.

6. Control panel

6-1. Basic Operation

The buttons and indicators on the control panel operate as follows.

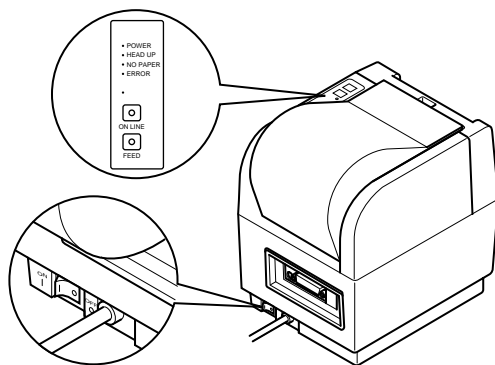

Fig. 6-1

ON LINE switch/indicator

Press the button to toggle the printer online or offline. The indicator lights up to indicate that the printer is online. When the printer goes offline, it ceases printing and becomes unable to receive data from the host.

NOTE: If the print head overheats during long continuous use, the printer automatically stops printing and the ON LINE indicator begins to flash. The printer will automatically resume printing when the print head cools down.

FEED switch

This switch's function changes depending on whether the Top of Form function is enabled or disabled. (See page 11.)

- When the Top of Form function is disabled (factory setting).
Each time the switch is pressed, the paper is fed by the amount of one line. If you continue to press it, the paper is fed continuously.
- When the Top of Form function is enabled.
Each time the switch is pressed, paper is fed to the top of form position. This operation can be performed whether the printer is in the on line state or the off line state.

POWER indicator

Lights up to indicate that the printer's power is on.

HEAD UP indicator

Lights up to indicate that the print head unit is unlocked. Do not try printing while this indicator is on. If this indicator comes on suddenly during printing, it is likely that a paper jam has pushed the print head unit out of position.

No Paper Indicator

This indicator lights up when the printer runs out of paper and when no paper is set.

When this indicator lights up, set a new roll of paper in the printer, then press the ON LINE switch.

Error Indicator

This indicator lights up whenever an error occurs in the printer.

6-2. Power switch and ON LINE/FEED switch combinations

The following can be set when the power switch is turned on.

1) Power + FEED switches

(Turn the power on while holding the FEED switch depressed.)

1 short beep ... Test print

2) Power + ON LINE switches

(Turn the power on while holding the ON LINE switch depressed.)

	Approx. 2 sec.		Approx. 2 sec.	
1 short beep	...	2 short beeps	...	3 short beeps
	a		b	c
HEAD UP LED		NO PAPER LED		ERROR LED
lights up		lights up		lights up

Pause at a: HEX dump

Pause at b: sensor selection

Press ON LINE	1 short beep	Reflecting sensor
Press FEED	2 short beeps	Transmissive sensor

Pause at c: command mode selection

Press ON LINE	1 short beep	Page mode
Press FEED	2 short beeps	Line mode

3) Power + ON LINE + FEED switches

(Turn the power on while holding the ON LINE and FEED switches depressed.)

	Approx. 2 sec.	Approx. 2 sec.	Approx. 2 sec.	Approx. 2 sec.	...
1 short beep	...	2 short beeps	...	3 short beeps	...
	a	b	c	d	e
HEAD UP LED lights up	NO PAPER LED lights up	ERROR LED lights up	LEDs flash successively lights up	All LEDs light up	...

Pause at a: RAM backup cleared

Pause at b: feed function selection

Press ON LINE	1 short beep	Top of Form disabled.
Press FEED	2 short beeps	Top of form enabled.

Pause at c: sensor adjustment mode

Pause at d: no operation

Pause at e: clearing of all memory switches and test print

- ① At e, release the ON LINE switch and FEED switch in 2 seconds or less (all LEDs go off).
 - ② Press the ON LINE switch and FEED switch in 2 seconds or less, and hold them depressed for at least 3 seconds (all LEDs light up).
 - ③ Release the ON LINE switch and FEED switch.
 - ④ The contents of all memory switches will be erased (all will be set to 0).
After that, test print is carried out.
- * If this process is interrupted midway, the printer will operate in regular mode.
 - * After the memory switch settings are erased, the memory switches must be set again, as appropriate for each model.

6-3. Print Density Adjustment

Since the sensitivity of different types of heat-sensitive paper varies, you can adjust the print density by varying the current supplied to the thermal head.

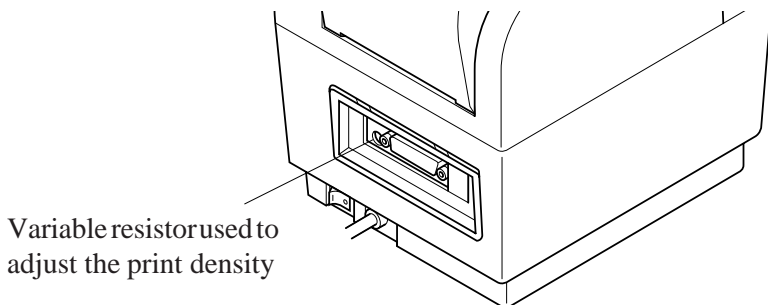

The print density can be adjusted using the variable resistor inside the hole beside the interface connector on the back of the printer.

1. To adjust the density turn the resistor roughly two times using a small cross-head screwdriver.
2. Turn the resistor to the right (clockwise) for a darker print density or to the left (counterclockwise) for a lighter density.

NOTE: If the density is increased to a higher level than necessary when printing on highly sensitive heat-sensitive paper, the dots may be too large and the print quality may decrease.

Excessively high energy adjustment may reduce head life.

6-4. Sensor Adjustment Mode

Sensor levels are adjusted at the factory. If necessary, you can readjust the levels as described below.

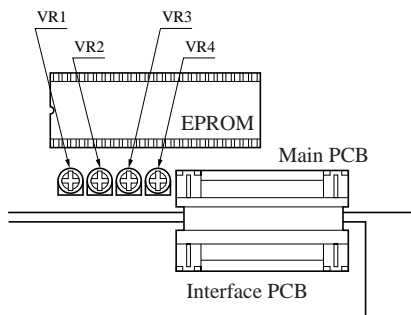

- 1) Make sure the printer is turned off.
- 2) Remove the ROM cover located beneath the paper-roll holding area.

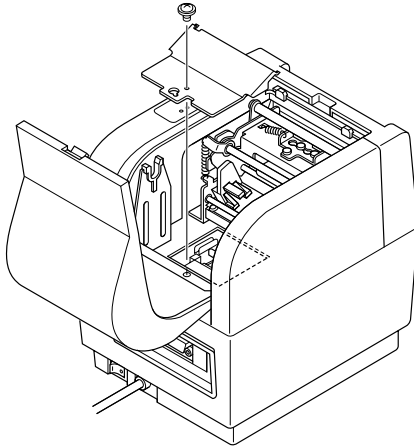

- 3) Hold down the FEED and ON LINE switches while switching on the power, and continue to hold them down until you hear a triple beep. (This will take about five seconds.) When you hear the triple beep, release the buttons to enter the sensor-adjustment mode.

a) Reflective Sensor

- Insert a non-black piece of paper into the mechanism's sensor area.
- Rotate the main PCB's sensor adjustment knob (VR4) to the point where the HEAD UP indicator comes on.

b) Paper-Out Sensor

- Insert a non-black piece of paper into the mechanism's sensor area.
- Rotate the main PCB's sensor adjustment knob (VR3) to the point where the NO PAPER indicator comes on.

c) Transmissive Sensor

- Insert the backing portion of a label sheet into the mechanism's transmissive sensor area. (Insert the backing only, not the label itself.)
- Adjust the main PCB's coarse (VR1) and fine (VR2) adjustment knobs to the point where the ERROR indicator comes on.

NOTE: When inserting paper, be sure to lower the head so that it is close to its normal fixed position.

- 4) Replace the ROM cover. Then secure it with the screw. The settings take effect when you turn on the printer.

6-5. Errors

The various types of errors can be identified by the buzzer's sound and the lit LEDs or the test print result.

Buzzer: The circled numbers refer to the type of buzzer sound.

LED: The circle (○) indicates that the LED is lit up.

a) Recoverable errors

The printer goes off line (ON LINE LED goes off) when these errors occur. After the cause of the error is removed, operation of the printer should return after the ON LINE switch is pressed.

Error	Cause	Buzzer	LED		
			ERROR	HEAD UP	NO PAPER
Head up error	The head is up.	②		○	
No paper error	Paper is not installed.	③			○

b) Unrecoverable errors

The printer goes off line (ON LINE LED goes off) when these errors occur. Operation of the printer cannot be returned after the cause of the error is removed.

Error	Cause	Buzzer	LED		
			ERROR	HEAD UP	NO PAPER
Label size error	The paper size differs from the set size.	④			○
Command error *1	There is an error in the command.	⑤	○		
Cutting error	The paper was not cut properly.	⑤	○		○
Transmission error *2	There is an abnormality in the received data.	⑤	○	○	

*1 Only in page mode

*2 Only with the serial interface

If a framing error or a vertical parity error occurs in Line Mode, “?” is printed.

c) Other errors (only in page mode)

- Data errors (<ESC> “PC” command: defines character and bar code data)
A data error will occur if an invalid character or bar code type is selected or if the print result extends outside the print area. When a data error occurs, all commands become invalid (character strings and bar codes cannot be printed). However, the printer will not go off line and the LEDs will not light up.

6-6. Buzzer Sounding Variations

- ① On Line, Off Line
- ② Head up error
- ③ No paper error
- ④ Size error
- ⑤ Command error (*1), Cutting error, Transmission (*2)
- ⑥ Test print by the reset command
- ⑦ Buzzer sounded by command (Line mode only)
 - *1 Page mode only
 - *2 Serial interface only

①	—	50 ms
②	—————	100 ms × 3
③	-----	50 ms × 4 (twice)
④	-----	50 ms × 4
⑤	—————	1000 ms
⑥	—————	250 ms × 2
⑦	—	100 ms

TABLE DES MATIERES

1. DEBALLAGE ET INSPECTION	17
1-1. Déballage	17
1-2. Remarques sur la manipulation	17
2. IDENTIFICATION DES PIECES ET NOMENCLATURE	18
3. INSTALLATION DU TORE DE FERRITE *EUROPE UNIQUEMENT ...	19
3-1. Interface parallèle	19
3-2. Câble de périphérique	20
4. RACCORDEMENT DU CÂBLE D'INTERFACE	21
4-1. Interface série	21
4-2. Interface parallèle	21
5. INSTALLATION	22
5-1. Chargement du rouleau de papier	22
5-2. Réglage de la position de la tête	24
6. TABLEAU DE COMMANDE	25
6-1. Fonctionnement de base	25
6-2. Combinaison d'interrupteur d'alimentation et de commutateur ON LINE/FEED ...	26
6-3. Réglage de la densité d'impression	28
6-4. Mode d'ajustement de capteur	28
6-5. Erreurs	30
6-6. Variations de tonalité de l'avertisseur sonore	31

L'appendice n'est pas traduit.

1. Déballage et inspection

1-1. Déballage

Vérifier chaque pièce de la boîte en se référant à la Fig. 1-1 afin de s'assurer qu'on a bien tout reçu.

En cas d'absence d'une de ces pièces, contacter le fournisseur.

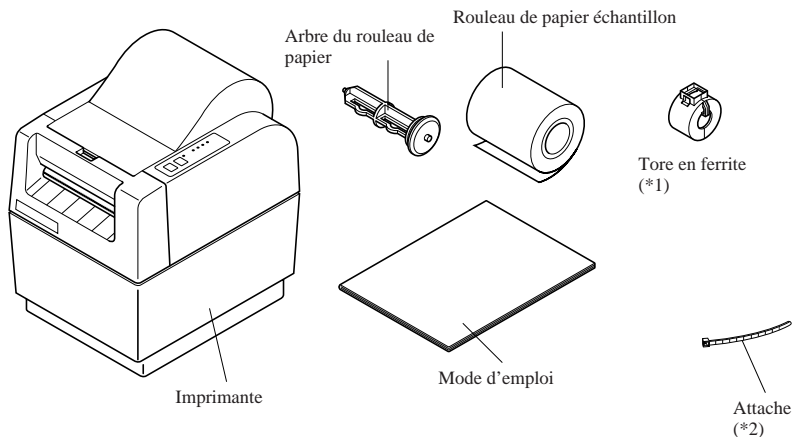

*1 Le tore de ferrite est inclus seulement pour les imprimantes vendues en Europe.

Deux sont prévus pour les modèles à interface parallèle et un pour les modèles à interface série.

*2 L'attache est incluse seulement pour les imprimantes vendues en Europe.

Fig. 1-1

1-2. Remarques sur la manipulation

Avant de commencer l'installation de l'imprimante, s'assurer qu'on dispose bien d'un endroit approprié pour la mettre. Un "endroit approprié" doit satisfaire aux conditions suivantes:

- A proximité d'une prise d'accès facile
- Surface ferme et à niveau pratiquement sans aucunes vibrations
- A distance de toute chaleur excessive (par exemple lumière du soleil directe, radiateurs etc.)
- A distance de toute humidité excessive
- A distance de poussière excessive
- Accès à une source d'alimentation constante ne subissant pas de pointes d'alimentation. Ainsi, par exemple, il ne faut pas relier l'imprimante au même circuit qu'un appareil important bruyant du genre réfrigérateur ou climatiseur.

REMARQUE: S'assurer que la tension de ligne correspond à la tension indiquée sur la plaque signalétique de l'imprimante.

2. Identification des pieces et nomenclature

Se référer à la Fig. 2-1 pour se familiariser avec les composants et capacités de l'imprimante.

Couvercle d'imprimante

Protège la tête d'impression ainsi que d'autres composants internes de l'imprimante.

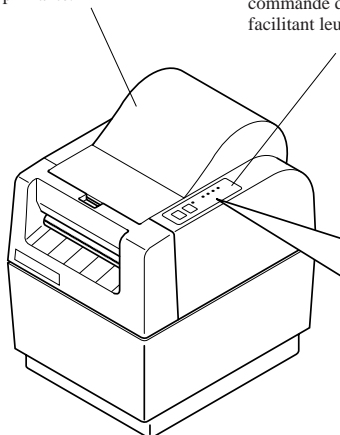

(TSP412Z)

Tableau de commande

Indique l'état de l'imprimante et simplifie les fonctions de commande de l'imprimante tout en facilitant leur exécution.

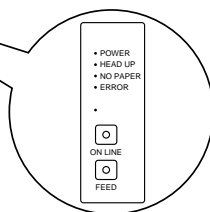

Couteau de papier automatique

(pilotage par commande)

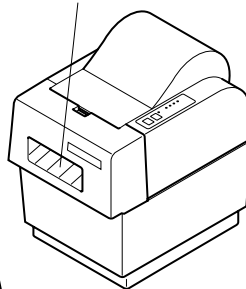

(TSP442Z)

Barre de déclenchement

Ouvre et ferme la tête d'impression qui retient le papier contre le cylindre.

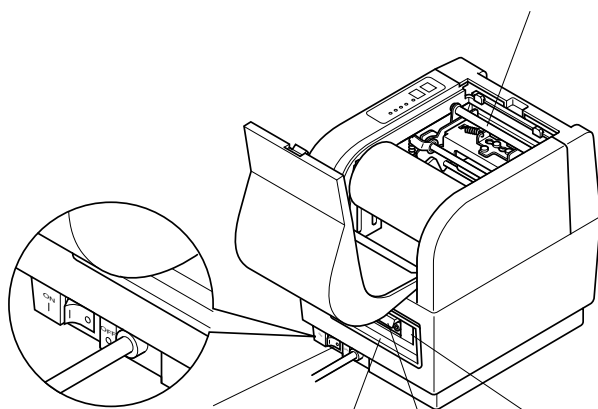

Interrupteur d'alimentation

Connecte ou coupe l'alimentation

Couvercle du connecteur

Connecteur d'interface

Relie l'ordinateur à l'imprimante

Connecteur d'entraînement de périphérique

Connexion uniquement à des périphériques de type caisse enregistreuse etc. ?
Ne pas raccorder à un téléphone.

Fig. 2-1

3. Installation du tore de ferrite *Europe uniquement

REMARQUE: Prendre des précautions spéciales en suivant les procédures indiquées ci-dessous:

3-1. Interface parallèle

- Les tores de ferrite sont livrés ouverts comme illustré en Fig. 3-2. Si un tore de ferrite n'est pas ouvert, utiliser un objet pointu pour forcer le verrouillage en plastique du tore de ferrite (Fig. 3-1). Ce faisant, prendre soin de ne pas endommager le tore en ferrite ni le verrouillage plastique.

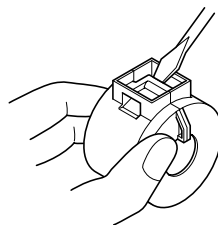

Fig. 3-1

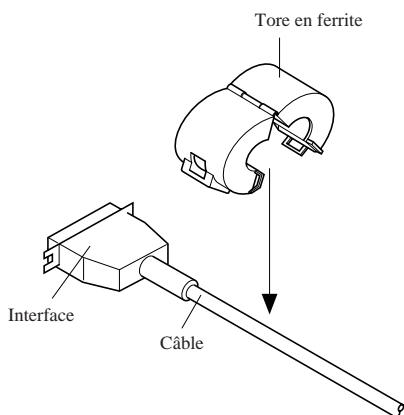
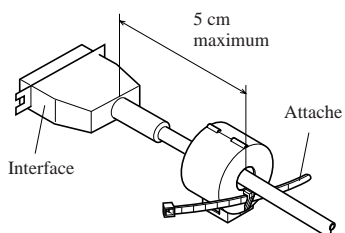
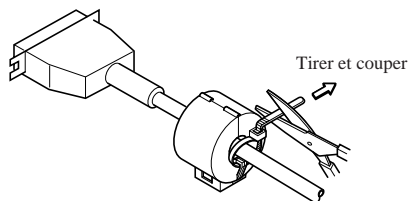

Fig. 3-2



Faire passer l'attache par le tore de ferrite

Fig. 3-3



Faire passer l'attache autour du câble et la bloquer. Couper toute partie qui dépasse avec des ciseaux.

Fig. 3-4

- Serrer le tore de ferrite au câble d'interface de la manière indiquée à la Fig. 3-2. Prendre les précautions d'usage pour éviter d'endommager le câble d'interface lors de l'installation du tore de ferrite. Il faut bien immobiliser le tore de ferrite au moyen de l'attache fournie, comme indiqué à la Fig. 3-3 et à la Fig. 3-4.

3-2. Câble de périphérique

- Fixer le plus grand des tores de ferrite sur le câble d'interface en procédant comme pour le tore de ferrite du câble d'interface parallèle. Dans le cas du tore de ferrite du câble de périphérique, mettre le câble en boucle comme illustré en Fig. 3-5.

REMARQUE: Les tores de ferrite doivent être attachés seulement pour l'Europe (seulement les imprimantes commercialisées en Europe sont concernées).
Installer à la fois le modèle interface parallèle et le modèle interface série.

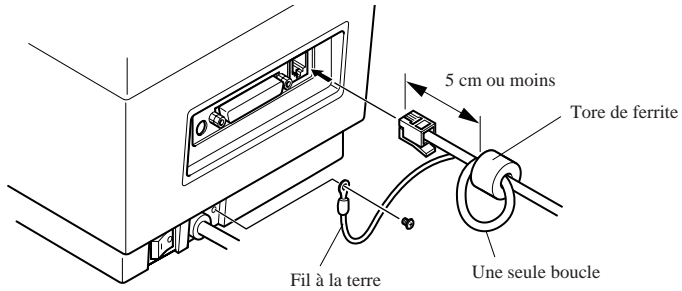
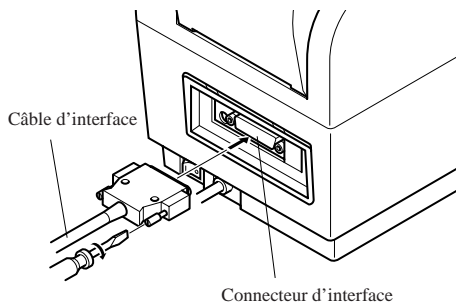

Fig. 3-5

4. Raccordement du câble d'interface

4-1. Interface série

Suivre les procédures indiquées ci-dessous pour relier le câble d'interface



- ① Couper l'alimentation à l'imprimante et à l'ordinateur.
- ② Insérer le câble d'interface dans le connecteur. (S'assurer que le câble est orienté correctement avant de l'insérer).
- ③ Serrer les vis droite et gauche pour les immobiliser sur le connecteur.
- ④ Relier l'autre extrémité du câble d'interface à l'ordinateur.

Fig. 4-1

REMARQUE: Rendre compatibles les conditions de transfert de données entre l'ordinateur et l'imprimante en réglant les microrupteurs de l'imprimante en conséquence. (Se référer à "ANNEXE").

4-2. Interface parallèle

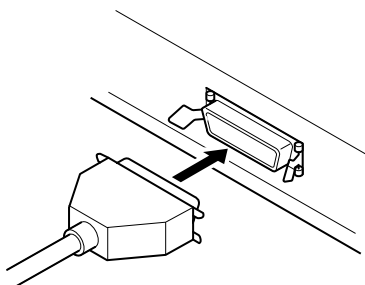

- ① Couper l'alimentation à l'imprimante et à l'ordinateur.
- ② Insérer le câble d'interface dans le connecteur. (S'assurer que le câble est orienté correctement avant de l'insérer).
- ③ Fermer les attaches du connecteur.
- ④ Relier l'autre extrémité du câble d'interface à l'ordinateur.

Fig. 4-2

5. Installation

- Commencer par enlever la bande bleue semi-transparente de toutes les pièces.
- Avant de charger le premier rouleau de papier, veiller à enlever le carton ainsi que le papier de protection (sous la barre de découpe) qui ont été insérés en vue de protection de la tête d'impression lors de l'expédition.

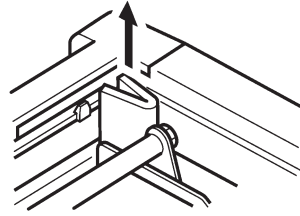

Fig. 5-1

5-1. Chargement du rouleau de papier

La procédure de chargement d'un rouleau de papier est décrite ci-dessous. Les illustrations décrivent l'imprimante TSP412Z. Mais il faut préciser que la procédure de chargement de l'imprimante TSP442Z est identique.

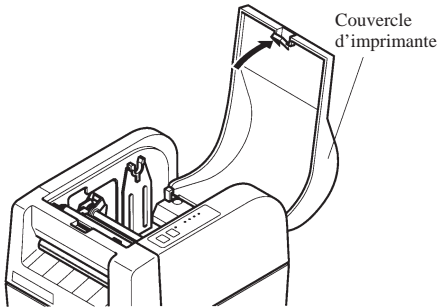

Fig. 5-2

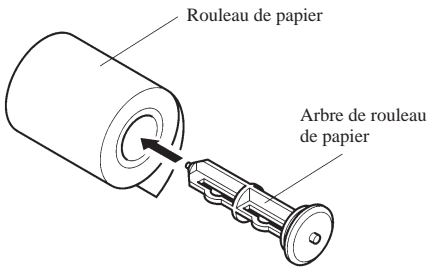

Fig. 5-3

- ① Eteindre l'alimentation de l'imprimante
- ② Ouvrir le couvercle de l'imprimante
- ③ Couper le bord supérieur du papier d'un bout à l'autre. Si l'extrémité du papier est immobilisée au rouleau par une étiquette ou par une bande, dérouler le papier d'un tour, puis le couper pour enlever toute trace d'adhésif. (Il est possible que l'adhésif colle au rouleau de papier interne et donc qu'il entrave l'avance du papier).
- ④ Insérer l'arbre du rouleau de papier dans le rouleau de papier.

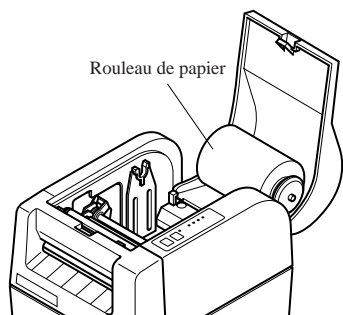

Fig. 5-4

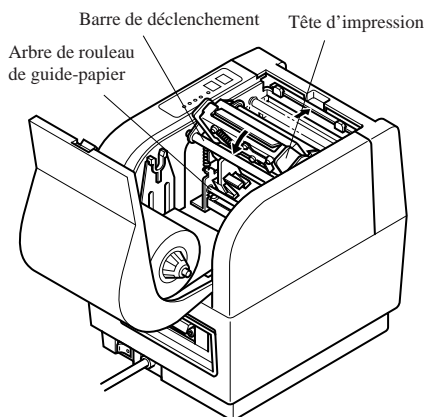

Fig. 5-5

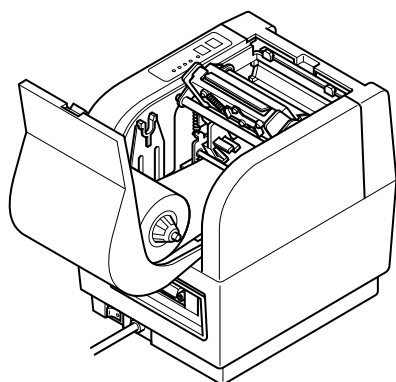

Fig. 5-6

- ⑤ Mettre le rouleau de papier sur le couvercle de l'imprimante à titre temporaire. S'assurer que le rouleau est orienté correctement en vue de chargement.
- ⑥ Tirer la barre de déclenchement verte de manière qu'elle se débloque, puis incliner la tête d'impression. Éviter de toucher des doigts la tête d'impression.
- ⑦ Insérer le papier de manière qu'il passe sous l'arbre du rouleau du guide-papier et entre les détecteurs de transmission.
- ⑧ Pousser le papier jusqu'à ce que le bord parvienne entièrement à la barre de découpe.

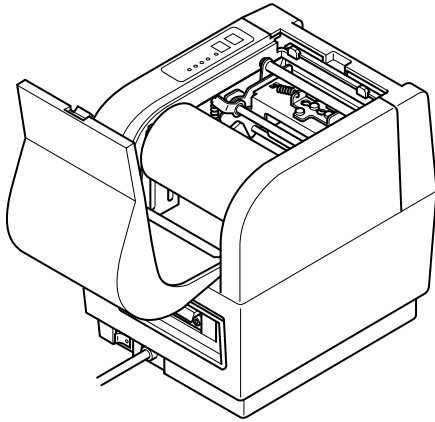

Fig. 5-7

- ⑨ Faire retourner la tête d'impression en position d'origine et s'assurer qu'elle se bloque en place. (Le couvercle d'imprimante ne fermera pas tant que la tête d'impression n'est pas bloquée).
- ⑩ Mettre le rouleau de papier sur le porte-rouleau de papier de l'imprimante.
- ⑪ Maintenir le rouleau abaissé et tirer le bord d'avance du papier afin d'éliminer tout jeu éventuel.
- ⑫ Close the printer cover.

5-2. Réglage de la position de la tête

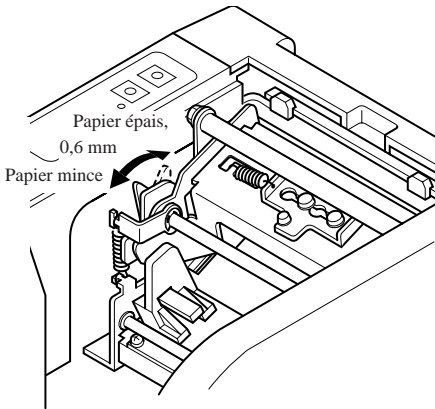

Fig. 5-8

- ① Il est possible de régler la position de la tête d'imprimante en vue d'acceptation de papier mince ou épais. Changer la position en faisant avancer ou reculer les leviers droit et gauche.
- ② Veiller à débloquer la tête d'impression avant de déplacer les leviers.

6. Tableau de commande

6-1. Fonctionnement de base

Les touches et témoins du tableau de commande fonctionnent de la manière suivante:

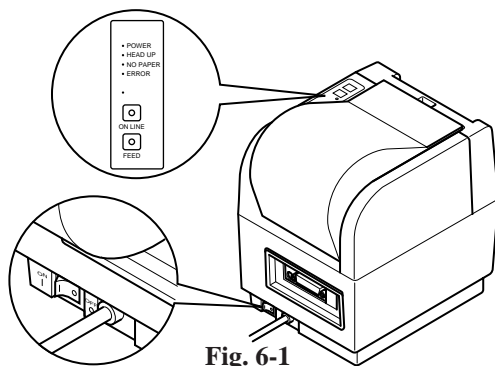

Fig. 6-1

Commutateur/Témoin ON LINE (EN LIGNE)

Appuyer sur la touche pour faire passer l'imprimante du mode en ligne au mode hors ligne. Le témoin s'allume pour indiquer que l'imprimante est en ligne. Lorsque l'imprimante passe en mode hors ligne, elle s'arrête d'imprimer et elle ne peut plus recevoir de données de l'ordinateur.

REMARQUE: En cas d'échauffement de la tête d'impression lors d'une utilisation longue et continue, l'imprimante s'arrête d'imprimer automatiquement et le témoin ON LINE commence à clignoter. L'imprimante commence à imprimer automatiquement dès que la tête d'impression refroidit.

Commutateur FEED (AVANCE)

La fonction de ce commutateur change selon la validation ou non de la fonction Haut de forme. (Voir la page 27.)

- Quand la fonction Haut de forme est invalidée (réglage usine)
A chaque pression du commutateur, le papier avance d'une ligne.
En pressant en continu, le papier avance en continu.
- Quand la fonction Haut de forme est validée
A chaque pression du commutateur, le papier avance jusqu'au haut de la forme.
Cette opération est possible que l'imprimante soit en ligne ou non.

Pause à a: basculement HEX

Pause à b: sélection de capteur

Appuyer sur ON LINE	1 bip bref	capteur de réflexion
Appuyer sur FEED	2 bips brefs	erreur de transmission

Pause à c: sélection du mode de commande

Appuyer sur ON LINE	1 bip bref	mode page
Appuyer sur FEED	2 bips brefs	mode ligne

3) Interrupteur d'alimentation + commutateurs ON LINE + FEED

(Mettre sous tension quand les commutateurs ON LINE et FEED sont pressés.)

	Env. 2 sec.	Env. 2 sec.	Env. 2 sec.	Env. 2 sec.	Env. 2 sec.	...		
1 bip bref	...	2 bips brefs	...	3 bips brefs	...	1 bip long
	a		b		c		d	e
Le témoin HEAD UP s'allume.		Le témoin NO PAPER s'allume.		Le témoin ERROR s'allume.		Les témoins clignotent successivement		Tous les témoins s'allument

Pause à a: remise à zéro de la sauvegarde RAM

Pause à b: sélection de fonction d'alimentation

Appuyer sur ON LINE	1 bip bref	haut de formule invalidé
Appuyer sur FEED	2 bips brefs	haut de formule validé

Pause à c: mode d'ajustement de capteur

Pause à d: pas d'opération

Pause à e: remise à zéro de tous les commutateurs de mémoire et de l'impression de test

- ① A e, relâcher la commande ON LINE et la commande FEED au plus tard au bout de 2 secondes (toutes les LED s'éteignent).
 - ② Appuyer sur la commande ON LINE et la commande FEED au plus tard au bout de 2 secondes et laisser le doigt sur ces commandes pendant au moins 3 secondes (toutes les LED s'allument).
 - ③ Relâcher la commande ON LINE et la commande FEED.
 - ④ Le contenu de tous les commutateurs de mémoire est vidé (tous les commutateurs sont remis à 0).
L'impression d'essai est alors effectuée.
- * Si le processus est interrompu à mi-chemin, l'imprimante se met en fonction en mode normal.
 - * Une fois les réglages des commutateurs de mémoire effacés, ceux-ci doivent être à nouveau réglés conformément aux conditions pour chacun des modèles.

6-3. Réglage de la densité d'impression

La thermosensibilité des papiers variant d'un type à l'autre, il est possible de régler la densité d'impression en faisant varier le courant appliqué à la tête thermique.

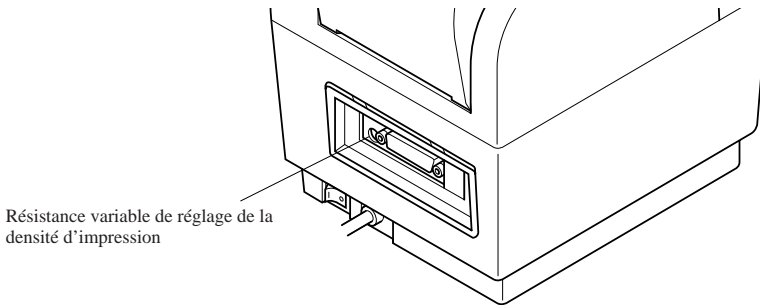

La densité d'impression est réglable à l'aide de la résistance variable se trouvant dans l'orifice ménagé à côté du connecteur d'interface au dos de l'imprimante.

1. Pour régler la densité d'impression, faire tourner la résistance variable d'environ deux tours à l'aide d'un tournevis à tête cruciforme.
2. Tourner vers la droite (sens horloger) pour régler sur une plus grande densité d'impression ou vers la gauche (sens contraire au sens horloger) pour une moindre densité.

REMARQUE: Si la densité est réglée sur un niveau trop élevé pour l'impression sur un papier à haute thermosensibilité, les points risquent d'être trop gros et la qualité d'impression moindre.

Un réglage à énergie trop élevée risque de réduire la durée de vie de la tête.

6-4. Mode d'ajustement de capteur

Les niveaux de détection sont ajustés à l'usine. Mais ils peuvent être réajustés comme indiqué ci-dessous.

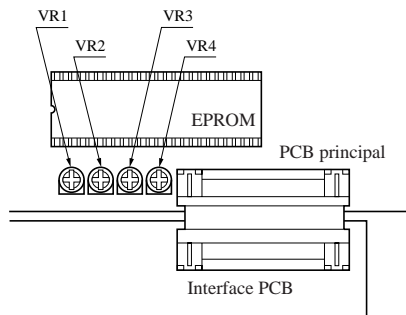

- 1) Vérifier que l'imprimante est coupée.
- 2) Retirer le couvercle ROM situé sous le logement du rouleau de papier.

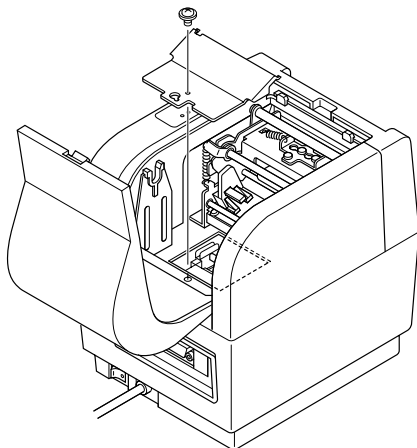

- 3) Maintenir les commutateurs FEED et ON LINE pressés en mettant sous tension, et continuer à les maintenir jusqu'au retentissement d'un triple bip (au bout d'environ cinq secondes). Après le triple bip, relâcher les commutateurs pour passer en mode d'ajustement de capteur.
 - a) Capteur de réflexion
 - Insérer une feuille sans zone noire dans la zone des capteurs du mécanisme.
 - Tourner le bouton d'ajustement du capteur PCB (VR4) jusqu'à l'emplacement où le témoin HEAD UP s'allume.
 - b) Capteur pas de papier
 - Insérer une feuille sans zone noire dans la zone des capteurs du mécanisme.
 - Tourner le bouton d'ajustement du capteur PCB (VR3) jusqu'à l'emplacement où le témoin NO PAPER s'allume.
 - c) Capteur de transmission
 - Insérer la partie arrière de la feuille à étiquettes dans la zone des capteurs de transmission du mécanisme. (Insérer la partie arrière seulement, pas les étiquettes.)
 - Ajuster les boutons d'ajustement approximatif (VR1) et précis (VR2) du PCB principal jusqu'à l'emplacement où le témoin ERROR s'allume.

REMARQUE: A l'insertion de la feuille, abaisser le haut de sorte qu'il soit proche de sa position de fixation normale.

- 4) Remettre le couvercle RCM en place. Le fixer à l'aide de la vis. Les réglages prennent effet dès que l'imprimante est mise en fonction.

6-5. Erreurs

Différents types d'erreur sont identifiables par le son de l'avertisseur sonore et les témoins allumés ou les résultats des impressions de test.

Avertisseur sonore: Les numéros encadrés indiquent le numéro du son de l'avertisseur sonore.

Témoin: Le cercle (○) indique que le témoin est allumé.

a) Erreurs réparables

L'imprimante se met hors ligne (le témoin ON LINE s'éteint) quand ces erreurs surviennent.

Une fois la cause de l'erreur éliminée, l'imprimante se remettra en fonctionnement après la pression du commutateur ON LINE.

Erreur	Cause	Avertisseur sonore	Témoin		
			ERREUR	TETE VERS LE HAUT	MANQUE PAPIER
Erreur tête levée	La tête est levée.	②		○	
Erreur papier épuisé	Il n'y a pas de papier.	③			○

b) Erreurs non réparables

L'imprimante se met hors ligne (le témoin ON LINE s'éteint) quand ces erreurs surviennent.

L'imprimante ne peut pas se remettre en fonctionnement après l'élimination de la cause de l'erreur.

Erreur	Cause	Avertisseur sonore	Témoin		
			ERREUR	TETE VERS LE HAUT	MANQUE PAPIER
Erreur taille d'étiquette	Le format du papier diffère de celui réglé.	④			○
Erreur de commande *1	Il y a une erreur de commande.	⑤	○		
Erreur de coupure	Le papier est mal coupé.	⑤	○		○
Erreur de transmission *2	Anomalie dans la réception des données.	⑤	○	○	

*1 Seulement en mode papier

*2 Seulement avec l'interface série

«?» s'imprime en cas d'erreur de cadrage ou d'erreur de parité verticale en mode ligne.

c) Autres erreurs (seulement en mode page)

- Erreur de données (commande «PC» <ESC>: définit les données de caractères et de code à barres) Une erreur de données surviendra si un type de caractère ou de code à barres invalide est sélectionné ou si le résultat de l'impression s'étend au-delà de la zone d'impression. En cas d'erreur de données, toutes les commandes deviennent invalides (les trains de caractères et les codes à barres ne peuvent pas être imprimés). Mais l'imprimante ne se met pas hors ligne et les témoins ne s'allument pas.

6-6. Variations de tonalité de l'avertisseur sonore

- ① En ligne, hors ligne
- ② Erreur tête vers le haut
- ③ Erreur manque papier
- ④ Erreur de format
- ⑤ Erreur de commande (*1), Erreur de coupe, Erreur de transmission (*2)
- ⑥ Impression de test par commande de remise à zéro
- ⑦ Avertisseur sonore activé par commande (mode ligne seulement)
 - *1 Mode page seulement
 - *2 Interface série seulement

①	—	50 ms
②	— — — —	100 ms × 3
③	— — — — — — — —	50 ms × 4 (deux fois)
④	— — — —	50 ms × 4
⑤	—————	1000 ms
⑥	————— —————	250 ms × 2
⑦	—	100 ms

INHALTSVERZEICHNIS

1. AUSPACKEN UND KONTROLLE	33
1-1. Auspacken	33
1-2. Hinweise	33
2. FUNKTION UND BEZEICHNUNG DER EINZELNEN BAUTEILE	34
3. INSTALLATION DER FERRITKERNE *NUR EUROPA	35
3-1. Parallele Schnittstelle	35
3-2. Peripheriegerätkabel	36
4. ANSCHLUSS DES SCHNITTSTELLENKABELS	37
4-1. Serielle Schnittstelle	37
4-2. Parallele Schnittstelle	37
5. INBETRIEBNAHME	38
5-1. Einlegen der Papierrolle	38
5-2. Einstellung der Druckkopfposition	40
6. BEDIENFELD	41
6-1. Grundlegender Betrieb	41
6-2. Kombinationen von Netzschalter und den Schaltern ON LINE/FEED	42
6-3. Einstellung der Druckdichte	44
6-4. Sensoreinstellmodus	44
6-5. Fehler	46
6-6. Summertonevariationen	47

Der Anhang erscheint nur im englischen Teil dieser Bedienungsanleitung

1. Auspacken und Kontrolle

1-1. Auspacken

Überprüfen Sie an Hand von Abb. 1-1 die Teile in der Verpackung, und stellen Sie sicher, daß alle nötigen Positionen geliefert wurden.

Falls eines der Teile fehlen sollte, wenden Sie sich bitte an Ihren Händler.

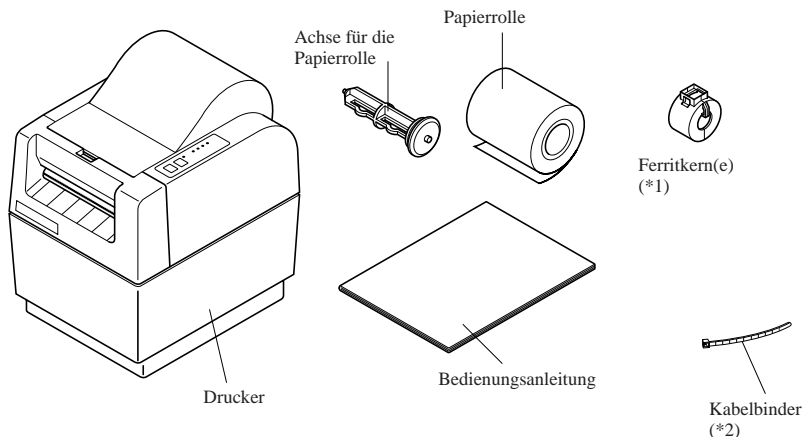

*1 Der Ferritkern wird nur für in Europa vertriebene Drucker mitgeliefert.

Für Modelle mit paralleler Schnittstelle werden jeweils zwei Ferritkerne geliefert, während für Modelle mit serieller Schnittstelle jeweils ein Ferritkern geliefert wird.

*2 Ein Kabelbinder wird nur für in Europa vertriebene Drucker mitgeliefert.

Abb. 1-1

1-2. Hinweise

Wählen Sie für die Aufstellung Ihres Druckers zunächst einen geeigneten Platz aus. Er sollte folgende Merkmale aufweisen:

- Er sollte nahe einer leicht zugänglichen Netzsteckdose sein.
- Er sollte eine stabile, ebene und erschütterungsfreie Oberfläche haben.
- Er sollte nicht übermäßiger Hitze ausgesetzt sein (wie direktem Sonnenlicht, einer Heizung usw.).
- In der Druckerumgebung sollte keine übermäßige Luftfeuchtigkeit herrschen.
- Sie sollte nicht übermäßig staubig sein.
- Die Stromversorgung sollte stabil und nicht anfällig für Störungen sein. Sie sollten den Drucker zum Beispiel nicht an einem Stromkreis zusammen mit großen, eventuell Störungen verursachenden Geräten wie Kühlschrank oder Klimaanlage betreiben.

HINWEIS: Stellen Sie sicher, daß die Spannung Ihres Stromnetzes der Betriebsspannung entspricht, die auf dem Typenschild des Druckers angegeben ist.

2. Funktion und Bezeichnung der einzelnen Bauteile

Machen Sie sich in Abb. 2-1 mit den Bestandteilen des Druckers und seinen Funktionen vertraut.

Druckerklappe

Sie schützt den Druckkopf und andere Bauteile im Inneren Ihres Druckers.

Bedienfeld

Es zeigt den Druckerstatus an, und mit ihm lassen sich die Druckerfunktionen bequem und einfach steuern.

Automatischer Papierschneider (befehlsgesteuert)

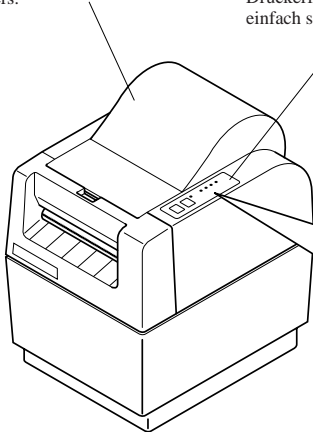

(TSP412Z)

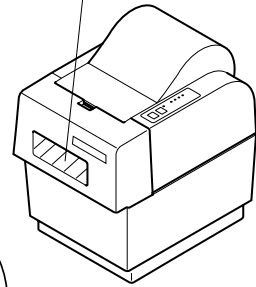
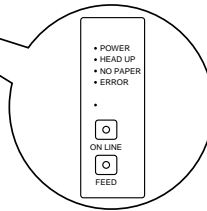

(TSP442Z)

Entriegelungshebel

Mit ihm wird die Druckkopfleinheit entlastet und angepreßt, mit der das Papier an die Walze gedrückt wird.

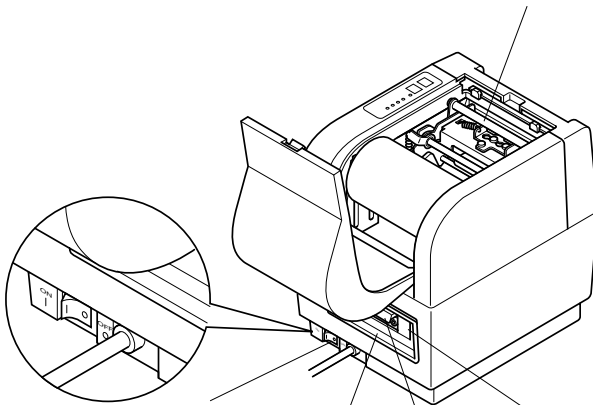

Netzschalter

Mit ihm wird das Gerät an- und ausgeschaltet.

Abdeckung für die Schnittstellenbuchse

Schnittstellenbuchse

An ihr wird der Computer an den Drucker angeschlossen.

Buchse für Peripheriegeräte

Nur zum Anschluß von Peripheriegeräten wie jede Geldlade usw. Nicht zum Anschluß an ein Telefon!

Abb. 2-1

3. Installation der Ferritkerne *Nur Europa

HINWEIS: Beachten Sie die folgenden Schritte besonders sorgfältig.

3-1. Parallele Schnittstelle

- Der Ferritkern wird offen geliefert, wie in Abb. 3-2 gezeigt. Sollte ein Ferritkern nicht offen sein, öffnen Sie den Plastikverschluß des Ferritkerns mit einem spitzen Gegenstand (Abb. 3-1). Achten Sie darauf, daß Sie weder den Ferritkern, noch den Plastikverschluß beschädigen, wenn Sie dies tun.



Abb. 3-1



Abb. 3-2

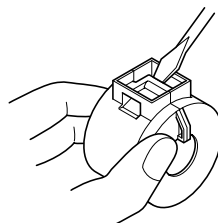

Führen Sie den Kabelbinder durch die Öse am Ferritkern.

Abb. 3-3

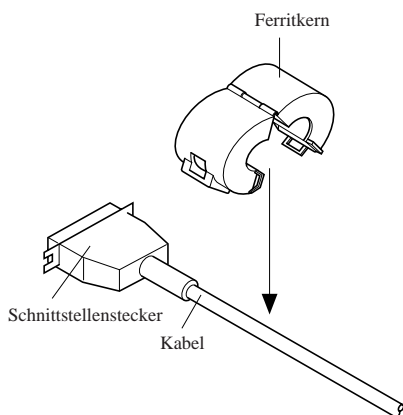
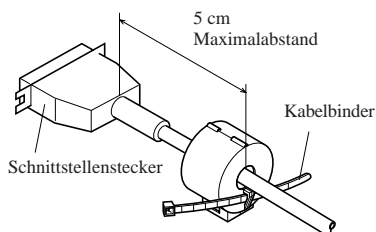
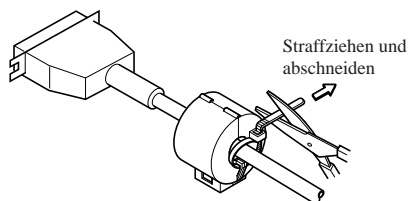

Führen Sie den Kabelbinder um das Kabel, und ziehen Sie ihn fest. Schneiden Sie das überstehende Ende mit einer Schere ab.

Abb. 3-4

- Klemmen Sie den Ferritkern wie in Abb. 3-2 gezeigt auf das Schnittstellenkabel. Achten Sie darauf, das Schnittstellenkabel beim Installieren des Ferritkerns nicht zu beschädigen. Der Ferritkern sollte wie in Abb. 3-3 und 3-4 gezeigt mit dem mitgelieferten Kabelbinder sicher verankert werden.

3-2. Peripheriegerät-kabel

- Klemmen Sie den großen Ferritkern auf die gleiche Weise wie für das Schnittstellenkabel beschrieben auf das Kabel für das Peripheriegerät. Bei diesem Ferritkern müssen Sie allerdings das Kabel wie in Abb. 3-5 gezeigt in einer Schlaufe führen.

HINWEIS: Die Ferritkerne brauchen nur für den europäischen Raum angebracht zu werden (trifft nur für in Europa auf den Markt gebrachte Drucker zu). Installieren Sie das parallele Schnittstellenmodell und das serielle Schnittstellenmodell.



Abb. 3-5

4. Anschluss des Schnittstellenkabels

4-1. Serielle Schnittstelle

Gehen Sie zum Anschluß des Schnittstellenkabels vor wie unten beschrieben.

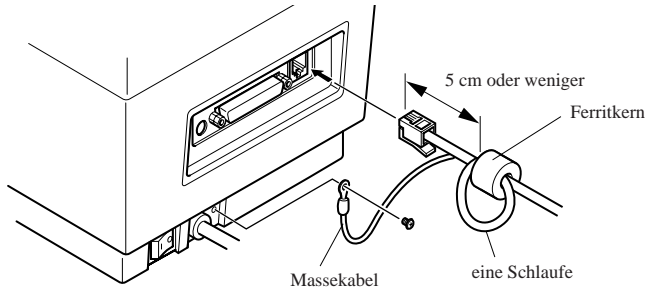

Abb. 4-1

- ① Schalten Sie Drucker und Computer aus.
- ② Stecken Sie das Schnittstellenkabel in die Buchse. (Vergewissern Sie sich, daß das Kabel korrekt ausgerichtet ist, bevor Sie den Stecker einstecken.)
- ③ Ziehen Sie die beiden Schrauben links und rechts fest, so daß der Stecker sicher an der Buchse befestigt ist.
- ④ Verbinden Sie das andere Ende des Kabels mit Ihrem Computer.

HINWEIS: Die Datenübertragungsparameter von Computer und Drucker müssen übereinstimmen. Sie werden mit den DIP-Schaltern des Druckers eingestellt (siehe »Anhang«).

4-2. Parallele Schnittstelle

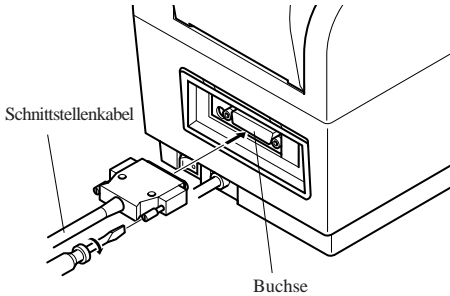

Abb. 4-2

- ① Schalten Sie Drucker und Computer aus.
- ② Stecken Sie das Schnittstellenkabel in die Buchse. (Vergewissern Sie sich, daß das Kabel korrekt ausgerichtet ist, bevor Sie den Stecker einstecken.)
- ③ Klammern Sie den Stecker an der Buchse fest.
- ④ Verbinden Sie das andere Ende des Kabels mit Ihrem Computer.

5. Inbetriebnahme

- Entfernen Sie zunächst das halbtransparente, blaue Klebeband von allen Teilen.
- Stellen Sie vor dem ersten Einlegen der Papierrolle sicher, daß das Pappstück und das Papier (unter der Abreißkante) entfernt worden ist. Diese Teile dienen dem Schutz des Druckkopfes beim Transport.

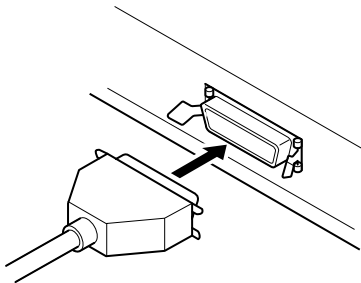

Abb. 5-1

5-1. Einlegen der Papierrolle

Gehen Sie beim Einlegen einer Papierrolle wie folgt vor. Die Abb. zeigt den Drucker TSP412Z, aber das Verfahren zum Einlegen ist das gleiche für den TSP442Z.

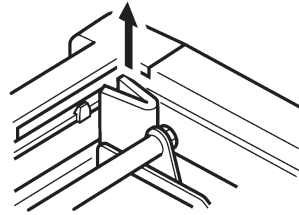

Abb. 5-2

- ① Schalten Sie den Drucker aus.
- ② Öffnen Sie die Druckerklappe

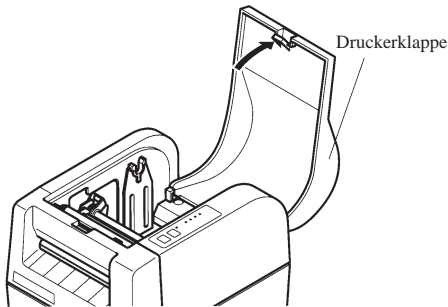

Abb. 5-3

- ③ Schneiden Sie die obere Kante des Papier gerade auf. Falls das Papierende mit einem Aufkleber oder einem Stück Klebeband gesichert ist, rollen Sie eine Windung Papier ab, und schneiden Sie Papier mit Klebstoffresten vollständig ab. (Der Klebstoff könnte an der Papierförderrolle im Inneren des Druckers haften bleiben und den Papiertransport behindern.)
- ④ Stecken Sie die Achse in die Papierrolle.



Abb. 5-4

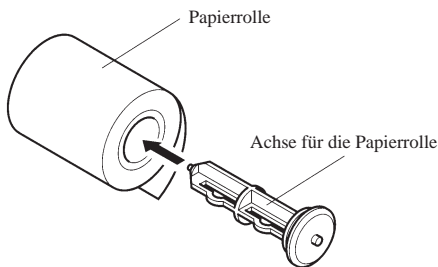

Abb. 5-5

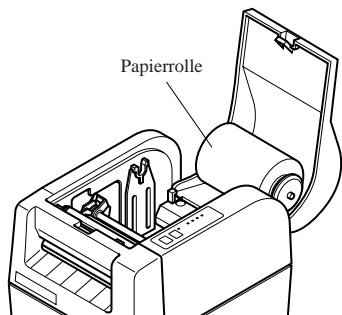

Abb. 5-6

⑤ Legen Sie die Papierrolle vorübergehend in den Druckerdeckel. Achten Sie darauf, daß die Rolle zum Einlegen bereits richtig herum liegt.

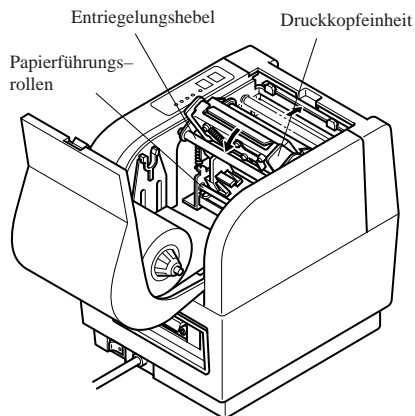
⑥ Ziehen Sie den grünen Entriegelungshebel, so daß er löst; kippen Sie dann die Druckkopfeinheit. Vermeiden Sie es, den Druckkopf mit den Fingern zu berühren.

⑦ Führen Sie das Papier so ein, daß es unter der Papierführungsrolle und zwischen den Transportsensoren hindurch läuft.

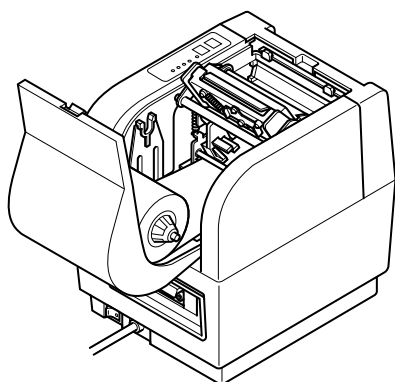
⑧ Ziehen Sie das Papier so weit durch den Drucker, bis die Abreißkante erreicht ist.



Abb. 5-7

- ⑨ Kippen Sie den Druckkopf zurück in seine Ausgangsstellung. Vergewissern Sie sich, daß der Druckkopf eingerastet ist. (Der Druckerdeckel kann nicht geschlossen werden, solange der Druckkopf nicht eingerastet ist.)
- ⑩ Legen Sie die Papierrolle in den Papierrollenhalter des Druckers.
- ⑪ Halten Sie die Rolle fest, und ziehen Sie am Papierende das Papier straff.
- ⑫ Schließen Sie den Druckerdeckel.

5-2. Einstellung der Druckkopposition

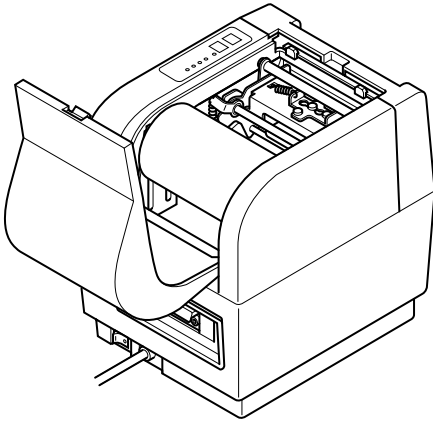

Abb. 5-8

- ① Sie können für dickes und dünnes Papier die Position des Druckkopfs jeweils passend einstellen. Die Position wird verändert, indem Sie die linken und rechten Hebel nach vorn oder nach hinten bewegen.
- ② Sie müssen vor dem Verstellen der Hebel den Druckkopf entriegeln.

6. Bedienfeld

6-1. Grundlegender Betrieb

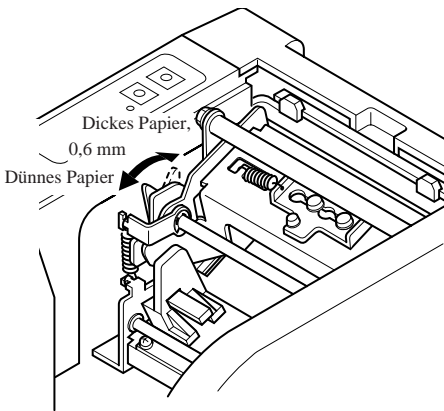
Die Tasten und Anzeigen des Bedienfeldes arbeiten wie im folgenden beschrieben.



Abb. 6-1

Schalter/Anzeige ON LINE

Mit dieser Taste wird zwischen den Drucker-Modi "Online" und "Offline" hin- und hergeschaltet. Die Anzeige leuchtet, wenn der Drucker online ist. Wenn der Drucker offline geht, wird der Druck gestoppt, und der Drucker kann keine Daten vom Computer empfangen.

HINWEIS: Wenn der Druckkopf während eines langandauernden, ununterbrochenen Gebrauchs überhitzt, stoppt der Drucker die Ausgabe automatisch, und die ON-LINE-Anzeige blinkt. Der Drucker setzt die Ausgabe automatisch fort, sobald der Druckkopf abgekühlt ist.

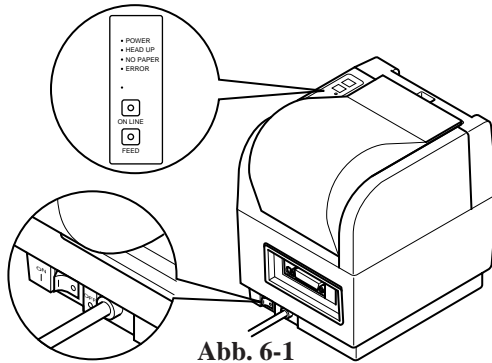
Schalter FEED

Die Funktion dieses Schalters ändert sich abhängig davon, ob die Funktion für Anfang des Formblattes wirksam ist oder nicht. (Siehe Seite 43.)

- Wenn die Funktion für Anfang des Formblattes unwirksam ist (Werkseinstellung)
Bei jedem Druck auf den Schalter wird das Papier um den Betrag einer Zeile transportiert.
Bei kontinuierlichem Drücken des Schalters wird das Papier kontinuierlich transportiert.
- Wenn die Funktion für Anfang des Formblattes wirksam ist
Bei jedem Druck auf den Schalter wird das Papier zum Anfang des Formblattes transportiert.
Diese Tätigkeit kann durchgeführt werden, während der Drucker in Online- oder Offlinemodus ist.

Anzeige POWER

Sie leuchtet, wenn der Drucker angeschaltet ist.

Anzeige HEAD UP

Sie leuchtet, wenn der Druckkopf nicht verriegelt ist. Versuchen Sie nicht zu drucken, wenn diese Anzeige leuchtet. Falls diese Anzeige plötzlich mitten im Druckvorgang aufleuchtet, ist es sehr wahrscheinlich, daß ein Papierstau die Druckkopfeinheit aus der korrekten Position gedrückt hat.

Kein-Papier-Anzeige

Diese Anzeige leuchtet auf, wenn dem Drucker das Papier ausgeht und kein Papier eingelegt wird.

Wenn diese Anzeige aufleuchtet, so legen Sie eine neue Papierrolle in den Drucker ein und drücken Sie dann den Schalter ON LINE.

Fehleranzeige

Diese Anzeige leuchtet auf, wenn ein Fehler im Drucker auftritt.

6-2. Kombinationen von Netzschalter und den Schaltern ON LINE/FEED

Die folgenden Einstellungen können gemacht werden, wenn der Netzschalter eingeschaltet ist.

1) Netzschalter + Schalter FEED

(Schalten Sie die Stromversorgung ein, während Sie den Schalter FEED gedrückt halten.)

1 kurzer Piepton ... Prüfdruck

2) Netzschalter + Schalter ON LINE

(Schalten Sie die Stromversorgung ein, während Sie den Schalter ON LINE gedrückt halten.)

	Etwa 2 Sekunden		Etwa 2 Sekunden	
1 kurzer Piepton	...	2 kurze Pieptöne	...	3 kurze Pieptöne ...
	a		b	c

Die LED HEAD UP
leuchtet auf.

Die LED NO PAPER
leuchtet auf.

Die LED ERROR
leuchtet auf.

Pause bei a: Hexadezimal-Speicherauszug

Pause bei b: Sensorwahl

Drücken Sie ON LINE	1 kurzer Piepton	Reflektierender Sensor
Drücken Sie FEED	2 kurze Pieptöne	Durchlässiger Sensor

Pause bei c: Befehlsmoduswahl

Drücken Sie ON LINE	1 kurzer Piepton	Seitenmodus
Drücken Sie FEED	2 kurze Pieptöne	Zeilenmodus

3) Netzschalter + Schalter ON LINE + Schalter FEED

(Schalten Sie die Stromversorgung ein, während Sie den Schalter ON LINE und den Schalter FEED gedrückt halten.)

	Etwa 2 Sekunden	Etwa 2 Sekunden	Etwa 2 Sekunden	Etwa 2 Sekunden	...
1 kurzer Piepton ...	2 kurze Pieptöne ...	3 kurze Pieptöne...	1 langer Piepton
	a	b	c	d	e
Die LED HEAD UP leuchtet auf.	Die LED NO PAPER leuchtet auf.	Die LED ERROR leuchtet auf.	Die LEDs blinken der Reihe nach.	Alle LEDs leuchten auf.	

Pause bei a: RAM-Sicherungskopie gelöscht

Pause bei b: Wahl der Papiereinzugfunktion

Drücken Sie ON LINE	1 kurzer Piepton	Anfang des Formblattes unwirksam
Drücken Sie FEED	2 kurze Pieptöne	Anfang des Formblattes wirksam

Pause bei c: Sensoreinstellmodus

Pause bei d: Kein Betrieb

Pause bei e: Löschen aller Speicherschalter und Prüfdruck

- ① Bei e, den Schalter ON LINE und den Schalter FEED innerhalb von 2 Sekunden loslassen (alle LEDs gehen aus).
 - ② Den Schalter ON LINE und den Schalter FEED innerhalb von 2 Sekunden drücken und mindestens 3 Sekunden gedrückt halten (alle LEDs leuchten auf).
 - ③ Den Schalter ON LINE und den Schalter FEED loslassen.
 - ④ Der Inhalt aller Speicherschalter wird gelöscht (alle Speicherschalter werden auf 0 gestellt).
Anschließend wird Prüfdrucken durchgeführt.
- * Wenn dieser Prozeß unterwegs unterbrochen wird, arbeitet der Drucker in regulärem Modus.
 - * Nach Löschen der Speicherschalttereinstellungen müssen die Speicherschalter erneut wie angemessen für jedes Modell eingestellt werden.

6-3. Einstellung der Druckdichte

Da sich die Empfindlichkeit verschiedener Arten von wärmeempfindlichem Papier unterscheidet, können Sie die Druckdichte durch Variieren des dem Druckkopf zugeführten Stroms einstellen.

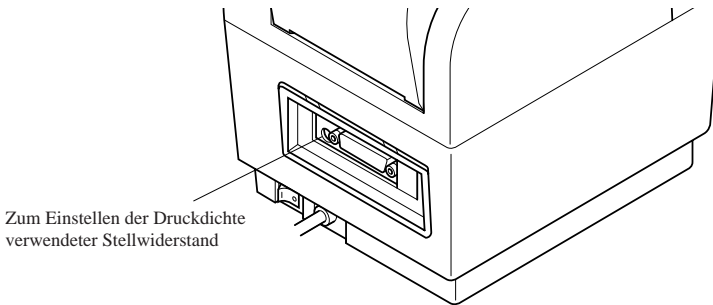

Die Druckdichte kann mit dem Stellwiderstand in der Öffnung neben dem Schnittstellenanschluß auf der Rückseite des Druckers eingestellt werden.

1. Drehen Sie den Stellwiderstand zum Einstellen der Dichte mit einem kleinen Kreuzschlitzschraubenzieher etwa zwei Umdrehungen.
2. Drehen Sie den Stellwiderstand für dunkleren Druck nach rechts (im Uhrzeigersinn) oder für helleren Druck nach links (gegen den Uhrzeigersinn).

HINWEIS: Wenn bei Drucken auf sehr wärmeempfindliches Papier hoher Empfindlichkeit die Dichte stärker als erforderlich eingestellt wird, so können die Punkte zu groß werden und die Druckqualität kann abnehmen. Übermäßig hohe Energieeinstellung kann die Lebensdauer des Druckkopfes verringern.

6-4. Sensoreinstellmodus

Die Sensorpegel werden im Werk eingestellt. Wenn erforderlich, können Sie die Pegel wie nachfolgend beschrieben neu einstellen.

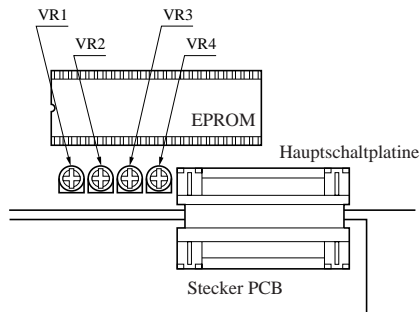

- 1) Stellen Sie sicher, daß der Drucker ausgeschaltet ist.
- 2) Entfernen Sie die ROM-Abdeckung unter dem Papierrollen-Haltebereich.

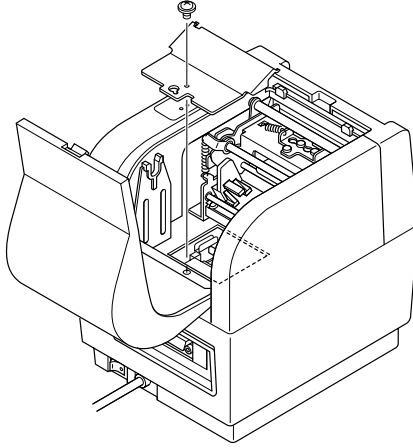

- 3) Halten Sie die Schalter FEED und ON LINE gedrückt, während Sie die Stromversorgung einschalten, und halten Sie die Schalter gedrückt, bis Sie einen dreifachen Piepton hören. (Dies dauert etwa 5 Sekunden.) Lassen Sie die Tasten los, wenn Sie den dreifachen Piepton hören, um in den Sensoreinstellmodus einzutreten.

a) Reflektierender Sensor

- Schieben Sie den nicht schwarzen Teil eines Blattes Papier in den Sensorbereich des Mechanismus ein.
- Drehen Sie den Sensoreinstellknopf (VR4) der Hauptschaltplatine zu dem Punkt, an dem die Anzeige HEAD UP aufleuchtet.

b) Kein-Papier-Sensor

- Schieben Sie den nicht schwarzen Teil eines Blattes Papier in den Sensorbereich des Mechanismus ein.
- Drehen Sie den Sensoreinstellknopf (VR3) der Hauptschaltplatine zu dem Punkt, an dem die Anzeige NO PAPER aufleuchtet.

c) Durchlässiger Sensor

- Schieben Sie den Stützteil eines Etikettenblattes in den Bereich für den durchlässigen Sensor des Mechanismus. (Schieben Sie nur den Stützteil und nicht das Etikett selbst ein.)
- Stellen Sie die Grob- und Feineinstellknöpfe (VR1 und VR2) der Hauptschaltplatine auf den Punkt ein, an dem die Anzeige ERROR aufleuchtet.

HINWEIS: Beim Einschieben von Papier darauf achten, den Kopf so abzusenken, daß er nahe an der normalen fixierten Position ist.

- 4) Bringen Sie die RCM-Abdeckung wieder an und sichern Sie sie mit einer Schraube.
Die Einstellungen werden wirksam, wenn Sie den Drucker einschalten.

6-5. Fehler

Die verschiedenen Fehlertypen können durch den Summertone und die aufleuchtenden LEDs oder das Ergebnis des Prüfdrucks identifiziert werden.

Summer: Die umkreiste Zahl bezeichnet den Typ des Summertons.

LED: Der Kreis (○) zeigt an, daß die LED leuchtet.

a) Behebbarer Fehler

Wenn diese Fehler eintreten, geht der Drucker in Offlinemodus (die LED ON LINE geht aus).

Nach Beseitigung der Fehlerursache sollte der Druckerbetrieb wieder aufgenommen werden, wenn der Schalter ON LINE gedrückt wird.

Fehler	Ursache	Summer	LED		
			ERROR	HEAD UP	NO PAPER
Druckkopf nicht verriegelt	Der Kopf ist oben.	②		○	
Kein Papier	Es ist kein Papier eingelegt.	③			○

b) Nicht behebbarer Fehler

Wenn diese Fehler eintreten, geht der Drucker in Offlinemodus (die LED ON LINE geht aus).

Nach Beseitigung der Fehlerursache kann der Druckerbetrieb nicht wieder aufgenommen werden.

Fehler	Ursache	Summer	LED		
			ERROR	HEAD UP	NO PAPER
Falsche Etikettgröße	Die Papiergröße unterscheidet sich von der eingestellten Größe.	④			○
Befehlsfehler *1	Im Befehl ist ein Fehler.	⑤	○		
Schneidfehler	Das Papier ist nicht richtig geschnitten.	⑤	○		○
Übertragungsfehler *2	Die empfangenen Daten sind nicht normal.	⑤	○	○	

*1 Nur im Seitenmodus

*2 Nur mit serieller Schnittstelle

Wenn ein Rahmungsfehler oder ein vertikaler Paritätsfehler im Zeilenmodus auftritt, wird «?» gedruckt.

c) Sonstige Fehler (nur im Seitenmodus)

- Datenfehler (<ESC> «PC»-Befehl: Definiert Zeichen- und Strichkodierten)
Ein Datenfehler tritt ein, wenn ein ungültiger Zeichen- oder Strichkodiertyp gewählt wird oder wenn das Druckergebnis den Druckbereich überschreitet. Wenn ein Datenfehler eintritt, werden alle Befehle ungültig (Zeichenketten und Strichcode können nicht gedruckt werden). Der Drucker geht jedoch nicht in Offlinemodus und die LEDs leuchten nicht auf.

6-6. Summertonevariationen

- ① Online-, Offlinemodus
- ② Druckkopf nicht verriegelt
- ③ Kein Papier
- ④ Größenfehler
- ⑤ Befehlsfehler (*1), Schneidfehler, Übertragungsfehler (*2)
- ⑥ Prüfdruck durch Rückstellbefehl
- ⑦ Summertone durch Befehl (nur im Zeilenmodus)

*1 Nur im Seitenmodus

*2 Nur mit serieller Schnittstelle

①	—	50 ms
②	_____	100 ms × 3
③	-----	50 ms × 4 (zweimal)
④	-----	50 ms × 4
⑤	—————	1000 ms
⑥	_____	250 ms × 2
⑦	—	100 ms

INDICE

1. APERTURA E CONTROLLO DELLA CONFEZIONE	49
1-1. Apertura della confezione	49
1-2. Avvertenze	49
2. IDENTIFICAZIONE E NOMENCLATURA DELLE PARTI	50
3. INSTALLAZIONE DEGLI ANELLI DI FERRITE *SOLO EUROPA	51
3-1. Interfaccia parallela	51
3-2. Cavo dell'unità periferica	52
4. COLLEGAMENTO DEL CAVO D'INTERFACCIA	53
4-1. Interfaccia seriale	53
4-2. Interfaccia parallela	53
5. INSTALLAZIONE	54
5-1. Caricamento del rotolo di carta	54
5-2. Regolazione della posizione della testina	56
6. PANNELLO DI CONTROLLO	57
6-1. Operazioni di base	57
6-2. Combinazioni di interruttore di accensione e interruttore ON LINE/ FEED ...	58
6-3. Regolazione della densità di stampa	60
6-4. Modalità di regolazione del sensore	60
6-5. Errori	62
6-6. Variazione del suono del cicalino	63

L'Appendice appare solo nella sezione in inglese di questo manuale.

1. Apertura e controllo della confezione

1-1. Apertura della confezione

Confrontare il contenuto della confezione con i componenti mostrati nella Fig. 1-1 per controllare di aver ricevuto tutto.

Nel caso mancasse qualcuna di queste parti, contattare il fornitore presso cui si è effettuato l'acquisto.

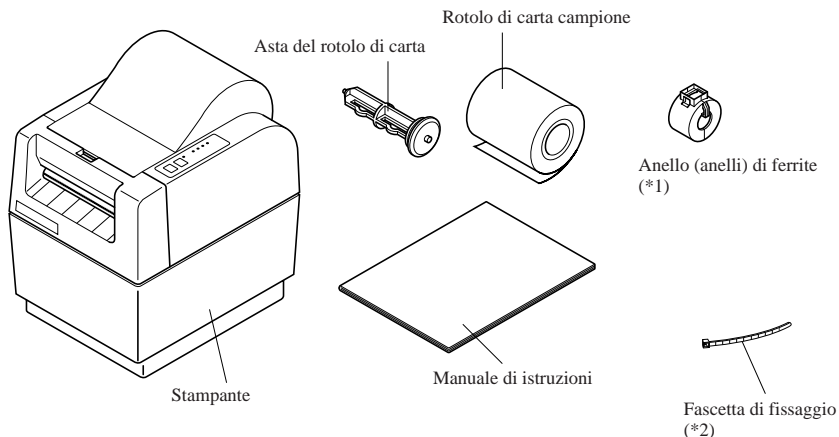

*1 L'anello di ferrite è incluso solo con le stampanti vendute in Europa.

Due pezzi sono per i modelli a interfaccia parallela e un pezzo è per il modello a interfaccia seriale.

*2 Una fascetta di fissaggio è inclusa solo con le stampanti vendute in Europa.

Fig. 1-1

1-2. Avvertenze

Prima dell'installazione della stampante, assicurarsi di disporre di un luogo adatto in cui collocarla. Per "luogo adatto", intendiamo un luogo:

- vicino ad una presa elettrica facilmente accessibile
- su una superficie solida e piana che non subisca vibrazioni
- lontano da fonti di calore eccessivo (come luce diretta del sole, apparecchi di riscaldamento, ecc.)
- lontano da umidità eccessiva
- lontano da polvere eccessiva
- con la possibilità di accedere ad una fonte di alimentazione elettrica stabile non soggetta a sbalzi improvvisi di tensione. Ad esempio, non collegare la stampante sullo stesso circuito elettrico di grossi apparecchi che producono disturbi come frigoriferi o condizionatori d'aria.

NOTA: Assicurarsi che la tensione del proprio impianto elettrico corrisponda a quella specificata sulla piastrina di identificazione della stampante.

2. Identificazione e nomenclatura delle parti

Esaminare la Fig. 2-1 per conoscere i componenti e le funzionalità della stampante.

Coperchio della stampante

Protegge la testina di stampa e gli altri componenti interni della stampante.

Pannello di controllo

Indica lo stato della stampante e semplifica il controllo delle funzioni della stampante.

Taglierina della carta automatica (Controllata tramite comando)

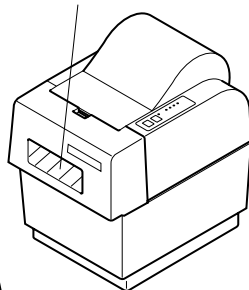
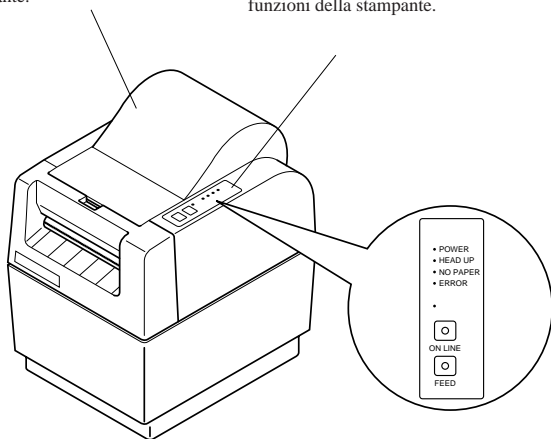

(TSP442Z)

(TSP412Z)

Barra di apertura

Serve per aprire e chiudere l'unità della testina di stampa che mantiene premuta la carta contro il rullo.

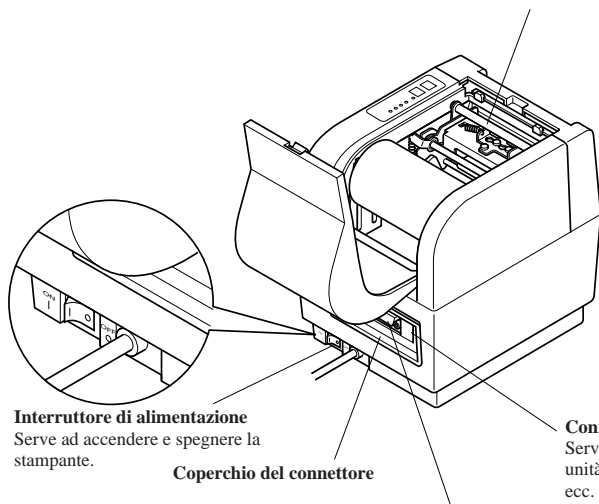

Interruttore di alimentazione

Serve ad accendere e spegnere la stampante.

Coperchio del connettore

Connettore d'interfaccia

Serve per collegare la stampante al computer.

Connettore unità periferica

Serve solo per collegare la stampante ad unità periferiche come registratori di cassa, ecc. Non collegarlo ad un telefono.

Fig. 2-1

3. Installazione degli anelli di ferrite *Solo europa

NOTA: Prestare particolare attenzione durante l'esecuzione delle procedure indicate di seguito.

3-1. Interfaccia parallela

- Gli anelli di ferrite sono confezionati aperti, come mostrato in Fig. 3-2. Se si trova uno degli anelli di ferrite chiuso, aprirlo utilizzando un oggetto appuntito per far leva sul dispositivo di chiusura di plastica dell'anello di ferrite (Fig. 3-1). Nel fare questo, fare attenzione a non danneggiare il nucleo di ferrite o il dispositivo di chiusura di plastica.

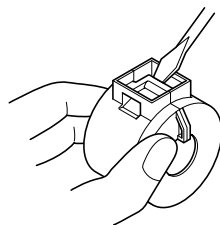

Fig. 3-1

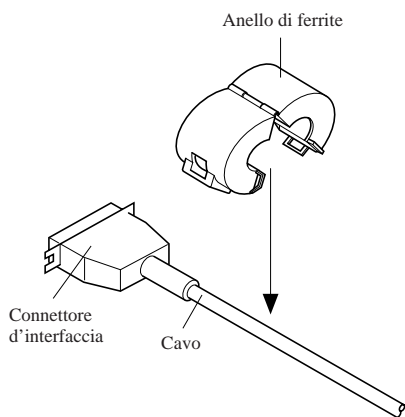
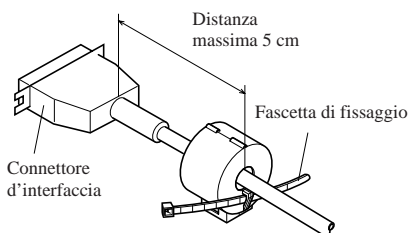
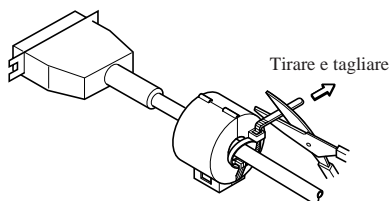

Fig. 3-2



Far passare la fascetta di fissaggio attraverso l'anello di ferrite.

Fig. 3-3



Far passare la fascetta di fissaggio intorno al cavo e bloccarla. Tagliare la parte in eccesso con delle forbici.

Fig. 3-4

- Fissare l'anello di ferrite sul cavo d'interfaccia come mostrato in Fig. 3-2, facendo attenzione a non danneggiare il cavo d'interfaccia quando si installa l'anello di ferrite. L'anello di ferrite va saldamente bloccato in posizione con la fascetta di fissaggio fornita in dotazione, come mostrato nelle Fig. 3-3 e 3-4.

3-2. Cavo dell'unità periferica

- Fissare l'anello di ferrite grande sul cavo dell'unità periferica eseguendo la stessa procedura vista di ferrite del cavo dell'interfaccia parallela. Tuttavia, quando si applica l'anello di ferrite sul cavo dell'unità periferica, è necessario fare un cappio al cavo come mostrato in Fig. 3-5.

NOTA: Gli anelli di ferrite devono essere applicati soltanto per l'area europea. (Hanno i requisiti soltanto le stampanti in vendita in Europa.)
Installare sia il modello di interfaccia parallela che il modello di interfaccia seriale.

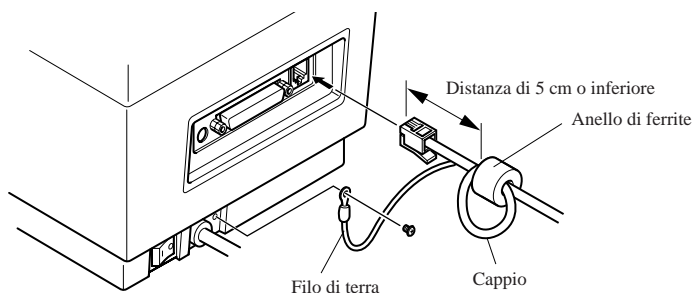
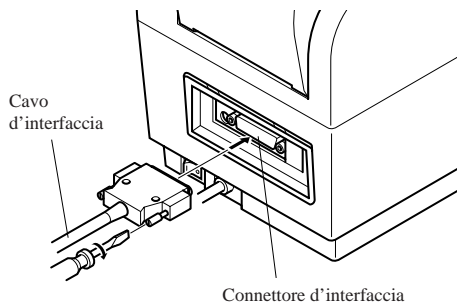

Fig. 3-5

4. Collegamento del cavo d'interfaccia

4-1. Interfaccia seriale

Per collegare il cavo d'interfaccia, eseguire le procedure indicate di seguito:



- ① Spegnere sia la stampante che il computer.
- ② Inserire il cavo d'interfaccia nel connettore (assicurarsi che il cavo sia orientato nel senso corretto prima di inserirlo).
- ③ Stringere le due viti di destra e sinistra per fissare il connettore.
- ④ Collegare l'altra estremità del cavo d'interfaccia al computer.

Fig. 4-1

NOTA: Le caratteristiche di trasferimento dati tra il computer e la stampante devono essere rese compatibili attraverso le impostazioni degli interruttori DIP della stampante (vedere l'“APPENDICE”).

4-2. Interfaccia parallela

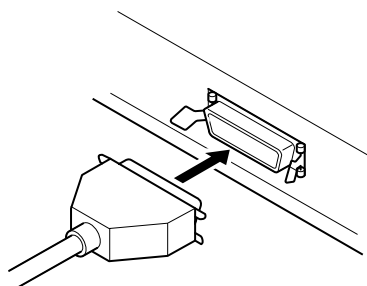

Fig. 4-2

- ① Spegnere sia la stampante che il computer.
- ② Inserire il cavo d'interfaccia nel connettore (assicurarsi che il cavo sia orientato nel senso corretto prima di inserirlo).
- ③ Bloccare i fermagli del connettore.
- ④ Collegare l'altra estremità del cavo d'interfaccia al computer.

5. Installazione

- Per prima cosa, staccare il nastro adesivo semitrasparente blu da tutti i componenti.
- Prima di caricare il primo rotolo di carta, assicurarsi di rimuovere il cartone ed il foglio di protezione (da sotto la barra di strappo) inseriti per proteggere la testina di stampa durante il trasporto.

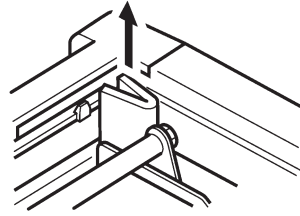

Fig. 5-1

5-1. Caricamento del rotolo di carta

La procedura per il caricamento di un rotolo di carta è illustrata di seguito. La stampante raffigurata è il modello TSP412Z. Tuttavia, la procedura per il caricamento relativa al modello TSP442Z è identica.

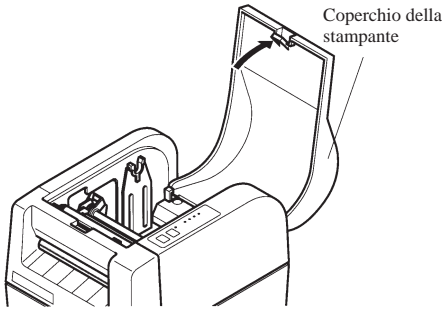

Fig. 5-2

- ① Spegner la stampante.
- ② Aprire il coperchio della stampante.

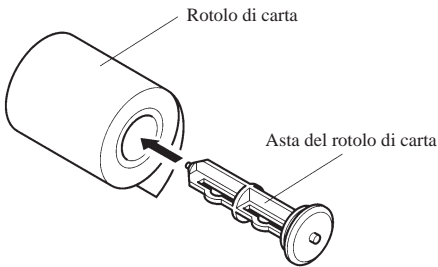

Fig. 5-3

- ③ Rifornire il bordo superiore della carta tagliandolo da parte a parte. Se il bordo della carta è fissato al rotolo con un'etichetta o con del nastro adesivo, srotolare di un giro la carta e tagliare tutta quella con tracce di adesivo (l'adesivo può attaccarsi al rullo interno ed ostacolare il trascinarsi della carta).
- ④ Inserire l'asta nel rotolo di carta.

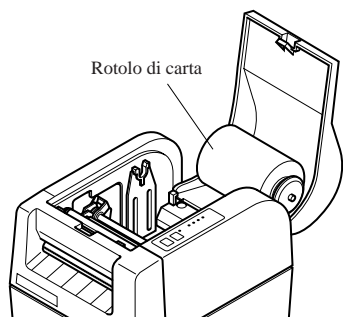

Fig. 5-4

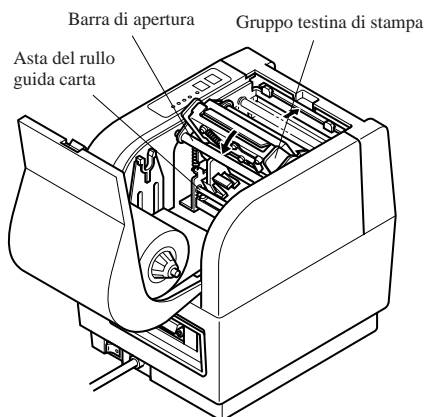

Fig. 5-5

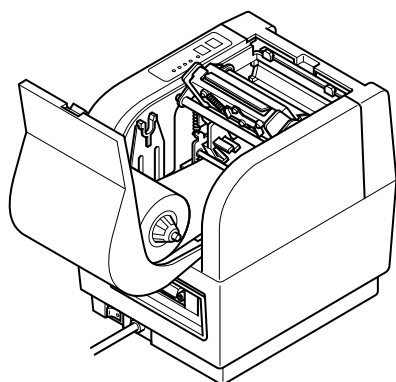

Fig. 5-6

⑤ Collocare provvisoriamente il rotolo di carta sul coperchio della stampante. Assicurarsi che il rotolo sia rivolto nel senso corretto per il caricamento.

⑥ Tirare la barra di apertura verde in modo da sbloccarla, quindi inclinare il gruppo testina di stampa. Evitare di toccare la testina di stampa con le dita.

⑦ Inserire la carta in modo da farla passare sotto l'asta del rullo guida carta e in mezzo ai sensori trasmettenti.

⑧ Spingere la carta fino a quando il bordo non si è spostato fino in fondo oltre la barra di strappo.

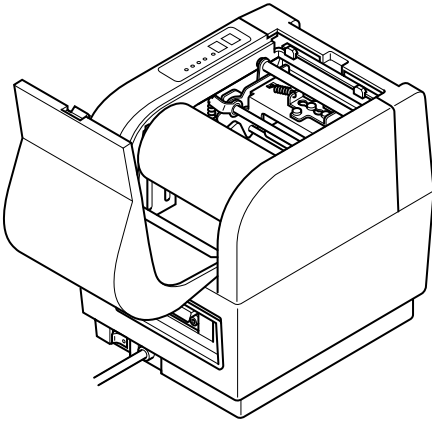

Fig. 5-7

- ⑨ Riportare il gruppo testina di stampa nella sua posizione originale ed assicurarsi che si blocchi in posizione (il coperchio della stampante non si chiude fino a quando il gruppo testina di stampa non è bloccato).
- ⑩ Spostare il rotolo di carta installandolo sui supporti del rotolo della stampante.
- ⑪ Tenere fermo il rotolo e tirare il bordo superiore della carta per mettere in tensione il rotolo.
- ⑫ Chiudere il coperchio della stampante.

5-2. Regolazione della posizione della testina

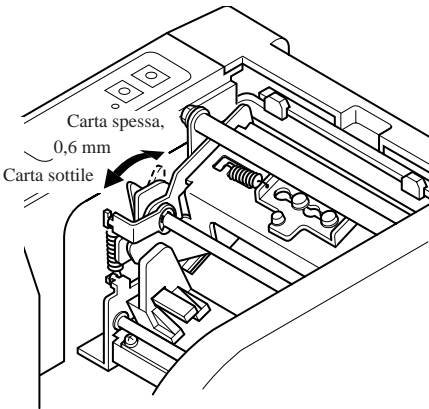

Fig. 5-8

- ① È possibile regolare la posizione della testina di stampa per permettere l'inserimento di carta spessa o sottile. Cambiare la posizione spostando in avanti o indietro le leve poste sui lati destro e sinistro.
- ② Assicurarsi di sbloccare la testina di stampa prima di spostare le leve.

6. Pannello di controllo

6-1. Operazioni di base

I pulsanti e le spie luminose del pannello di controllo funzionano come descritto di seguito.

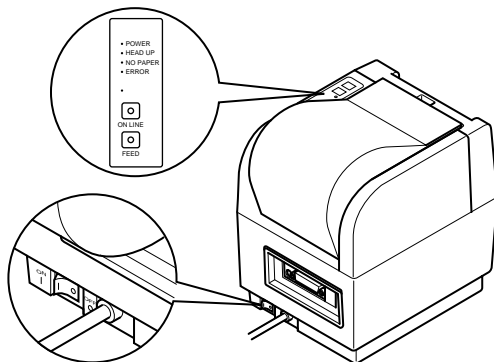

Fig. 6-1

Pulsante/spia ON LINE

Premere il pulsante per far passare la stampante dallo stato di online a quello di offline e viceversa. La spia si illumina per indicare che la stampante è online. Quando la stampante va in offline, interrompe la stampa e non può ricevere dati dal computer.

NOTA: Se la testina di stampa si surriscalda durante un lungo uso continuo, la stampante interrompe la stampa e la spia ON LINE inizia a lampeggiare. La stampante riprende automaticamente a stampare quando la testina di stampa si raffredda.

Pulsante FEED

questa funzione dell'interruttore cambia a seconda se la funzione Top of Form è abilitata o disabilitata. (Vedere pagina 59.)

- Se la funzione Top of Form è disabilitata (impostazione predefinita in fabbrica).
Ogni volta che si preme l'interruttore, la carta viene alimentata di una linea.
Se si continua a premere, la carta viene alimentata continuamente.
- Se la funzione Top of Form è abilitata.
Ogni volta che si preme l'interruttore, la carta viene alimentata nella posizione della parte superiore del foglio.
È possibile eseguire questa operazione sia che la stampante si trovi in stato on-line che in stato off-line.

Spia POWER

Si illumina per indicare che la stampante è accesa.

Spia HEAD UP

Si illumina per indicare che il gruppo testina di stampa è sbloccato. Non tentare di stampare mentre questa spia è accesa. Se la spia si accende improvvisamente nel corso della stampa, è probabile che della carta inceppata abbia spinto il gruppo testina di stampa fuori dal suo alloggiamento.

Spia di esaurimento carta

Questa spia si accende quando la stampante esaurisce la carta e quando non si inserisce nessun foglio di carta.

Quando si accende questa spia, inserire un nuovo rotolo di carta nella stampante, quindi premere l'interruttore ON LINE.

Spia di errore

Questa spia si accende tutte le volte che si verifica un errore nella stampante.

6-2. Combinazioni di interruttore di accensione e interruttore ON LINE/ FEED

Quando si accende l'interruttore, è possibile impostare quanto segue.

1) Interruttori accensione + FEED (ALIMENTAZIONE)

(Accendere l'alimentazione mentre si tiene premuto l'interruttore FEED)

1 breve segnale acustico ... Stampa di prova

2) Interruttori accensione + ON LINE

(Accendere l'alimentazione mentre si tiene premuto l'interruttore ON LINE)

Circa 2 sec.

Circa 2 sec.

1 breve segnale acustico ... 2 brevi segnali acustici ... 3 brevi segnali acustici ...

a

b

c

LED HEAD UP

si accende

LED NO PAPER

(CARTA FINITA)

si accende

LED ERROR

si accende

Pausa al punto a: Stampa memoria in ESADECIMALE

Pausa al punto b: Selezione sensore

Premere ON LINE 1 breve segnale acustico Sensore riflettente
Premere FEED 2 brevi segnali acustici Sensore trasmittente

Pausa al punto c: Selezione della modalità di comando

Premere ON LINE 1 breve segnale acustico Modalità pagina
Premere FEED 2 brevi segnali acustici Modalità linea

3) Interruttori accensione + ON LINE + FEED

(Accendere l'alimentazione mentre si tengono premuti gli interruttori ON LINE e FEED)

	Circa 2 sec.	Circa 2 sec.	Circa 2 sec.	Circa 2 sec.	...
1 breve segnale acustico	...	2 brevi segnali acustici	...	3 brevi segnali acustici	...
	a	b	c	d	e
HEAD UP LED si accende		NO PAPER LED si accende	ERROR LED si accende	1 LED lampeggiano in successione si accendono	Tutti i LED si accende

Pausa al punto a: Cancellazione del backup della RAM

Pausa al punto b: Selezione della funzione di alimentazione

Premere ON LINE 1 breve segnale acustico Disabilitata la funzione Top of Form (Parte superiore del figlio).
Premere FEED 2 brevi segnali acustici Abilitata la funzione Top of form.

Pausa al punto c: Modalità di regolazione del sensore

Pausa al punto d: Nessuna operazione

Pausa al punto e: Cancellazione di tutti gli interruttori di memoria e stampa di prova

- ① Al punto e rilasciare l'interruttore ON LINE e l'interruttore FEED in 2 secondi o meno (tutti i LED si spengono).
- ② Premere l'interruttore ON LINE e l'interruttore FEED in 2 secondi o meno e mantenerli premuti per almeno 3 secondi (tutti i LED si accendono).
- ③ Rilasciare l'interruttore ON LINE e l'interruttore FEED.
- ④ Il contenuto di tutti gli interruttori di memoria è cancellato (tutti sono impostati a 0).

In seguito viene eseguita la prova di stampa.

- * Se questo processo viene interrotto quando è in corso, la stampante funzionerà in modo regolare.
- * Dopo che le impostazioni degli interruttori di memoria sono cancellate, gli interruttori di memoria devono essere di nuovo impostati nel modo appropriato per ciascun modello.

6-3. Regolazione della densità di stampa

Poiché la sensibilità di diversi tipi di carta sensibile al calore varia, è possibile regolare la densità di stampa variando la corrente che arriva alla testina termica.

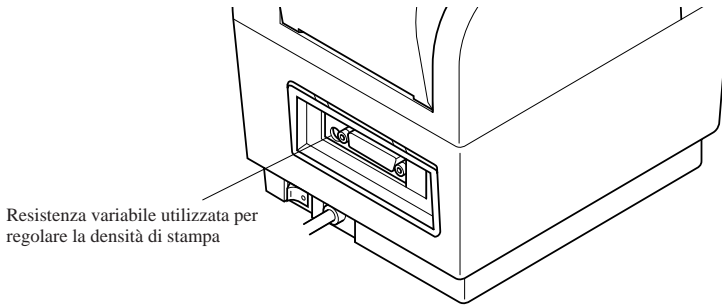

È possibile regolare la densità di stampa utilizzando la resistenza variabile che si trova all'interno del foro accanto al connettore dell'interfaccia situato dietro la stampante.

1. Per regolare la densità ruotare la resistenza circa due volte utilizzando un piccolo cacciavite a croce.
2. Ruotare la resistenza verso destra (in senso orario) per ottenere una maggiore densità di stampa (stampa più scura) oppure verso sinistra (in senso antiorario) per ottenere una minore densità di stampa (stampa più chiara).

NOTA: Se, quando si stampa su carta altamente sensibile al calore, si aumenta la densità a un livello superiore al necessario, i punti possono risultare troppo ampi e quindi la qualità di stampa può diminuire.

La regolazione che fornisce un'energia eccessivamente alta può ridurre la durata della testina.

6-4. Modalità di regolazione del sensore

I livelli del sensore sono regolati in fabbrica. Se necessario, è possibile regolare di nuovo i livelli nel modo descritto qui sotto.

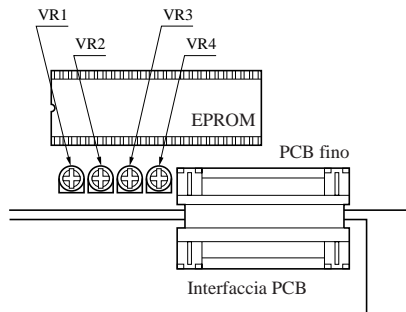

- 1) Accertarsi che la stampante sia spenta.
- 2) Rimuovere il coperchio della ROM situato al di sotto dell'area di supporto del rullo della carta.

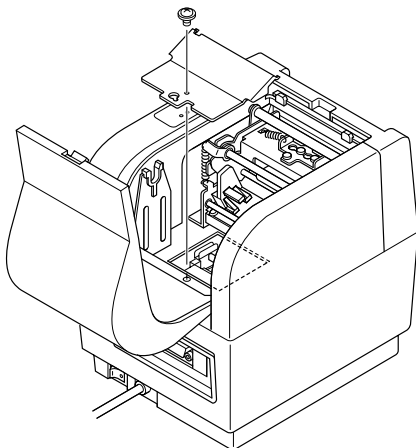

- 3) Mentre si accende l'alimentazione, tenere premuti gli interruttori FEED e ON LINE e continuare a tenerli premuti fino a quando non si ode un triplice segnale acustico. (Ci vorranno circa 5 secondi). quando si ode il triplice segnale acustico, rilasciare i tasti per entrare in modalità di regolazione del sensore.

a) Sensore riflettente

- Inserire un'area non-nera della carta nell'area del meccanismo del sensore.
- Ruotare la manopola principale di regolazione del sensore del PCB (VR4) fino al punto in cui si accende la spia HEAD UP.

b) Sensore di fine carta

- Inserire un'area non-nera della carta nell'area del meccanismo del sensore.
- Ruotare la manopola principale di regolazione del sensore del PCB (VR3) fino al punto in cui si accende la spia NO PAPER (CARTA FINITA).

c) Sensore trasmittente

- Inserire la porzione di rivestimento di un foglio di etichette nell'area del sensore trasmittente del meccanismo. (Inserire solo la porzione di rivestimento e non le etichette stesse.)
- Regolare la manopola di regolazione principale generale (VR1) e di precisione (VR2) del PCB fino al punto in cui si accende la spia ERROR.

NOTA: Quando si inserisce la carta, accertarsi di abbassare la testina, in modo che sia vicina alla sua normale posizione fissa.

- 4) Sostituire il coperchio RCM. Quindi, fissarlo con la vite. Le impostazioni diventano attive quando si accende la stampante.

6-5. Errori

È possibile identificare i vari tipi di errore tramite il suono del cicalino e i LED accesi oppure tramite i risultati della prova di stampa.

Cicalino: I numeri cerchiati si riferiscono al tipo di suono del cicalino.

LED: il cerchio (○) indica che il LED si è acceso.

a) Errori rimediabili

Quando si verificano questi errori, la stampante va off-line (si spegne il LED ON LINE). Dopo che è stata rimossa la causa dell'errore, la stampante dovrebbe riprendere a funzionare normalmente, dopo che si è premuto l'interruttore ON LINE.

Errore	Causa	Cicalino	LED		
			ERROR	HEAD UP	NO PAPER
Errore di testina su	La testina è su.	②		○	
Errore di esaurimento carta	Manca la carta.	③			○

b) Errori irrimediabili

quando si verificano questi errori, la stampante va off-line (si spegne il LED ON LINE). Non è possibile far funzionare nuovamente la stampante anche dopo che si è rimossa la causa dell'errore.

Errore	Causa	Cicalino	LED		
			ERROR	HEAD UP	NO PAPER
Errore di formato di etichette	Il formato della carta è diverso da quello impostato.	④			○
Errore di comando *1	C'è un errore nel comando.	⑤	○		
Errore di taglio	La carta non è stata tagliata correttamente.	⑤	○		○
Errore di trasmissione *2	È stata riscontrata un'anomalia nei dati ricevuti.	⑤	○	○	

*1 Solo in modalità Pagina.

*2 Solo con l'interfaccia seriale.

Se si verifica un errore di frame o un errore di parità verticale in modalità Linea, viene stampata l'indicazione «?».

c) Altri errori (Solo in modalità Pagina)

- Errore di dati (Comando <ESC> «PC»: definisce il carattere e i dati del codice a barre)
Si verifica un errore di dati se si seleziona un carattere o un tipo di codice a barre non validi o se i risultati di stampa si estendono al di fuori dell'area di stampa. Quando si verificano errori di dati, tutti i comandi diventano non validi (è impossibile stampare stringhe di caratteri e codici a barre). Tuttavia, la stampante non va off-line e i LED non si accendono.

6-6. Variazione del suono del cicalino

- ① On-line, Off-line
 - ② Errore di testina su
 - ③ Errore di esaurimento carta
 - ④ Errore di formato
 - ⑤ Errore di comando(*1),errore di taglio, errore di comunicazione(*2)
 - ⑥ Prova di stampa tramite il comando reset
 - ⑦ Suono del cicalino tramite comando (solo modalità Linea)
- *1 Solo modalità Pagina
*2 Solo interfaccia seriale

①	—	50 ms
②	— — — —	100 ms × 3
③	— — — — — — — —	50 ms × 4 (due volte)
④	— — — —	50 ms × 4
⑤	—————	1000 ms
⑥	————— —————	250 ms × 2
⑦	—	100 ms

Appendix A: Specifications

A-1. General Specifications

Printing system	Line thermal dot-matrix
Resolution	8 dots/mm (horiz.) × 8 dots/mm (vert.)
Printable width	Page Mode 80 mm Line Mode 75 mm
Printing speeds	640 dots line/sec (Max. 80 mm/sec.)
Interfaces	RS-232C, Bidirectional paral
Weight	TSP412Z: 3.4 kg TSP442Z: 3.7 kg
Power	(50/60Hz) AC120V, AC230V
Power consumption	Operating: Approx. 30W (During continuous printing of ASCII characters) Stand-by: Approx. 8W
Operating environment	+5 ~ +40 °C 25 ~ 85 % RH
Storage environment	-20 ~ +60 °C 10 ~ 90 % RH
Automatic paper cutter	
Life	300, 000 cuts (if paper debris is cleared)
Min. cut length	25.4mm (1 inch)

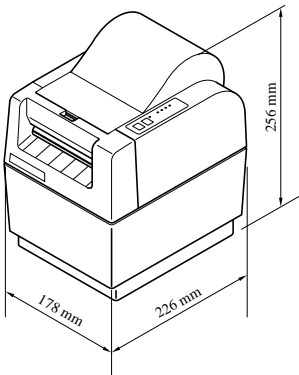

(TSP412Z)

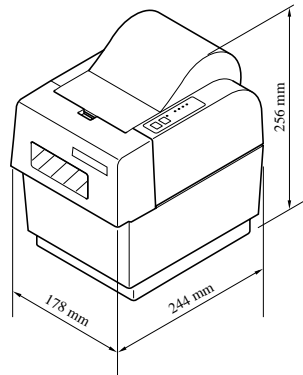

(TSP442Z)

A-2. Paper Specifications

Recommended paper-roll types:

Nippon Paper Industries	TF50KS-E (normal type paper) TF62KS-E (normal type paper)
Oji paper Co.,Ltd.	KF-730 (normal type paper)
Mitsubishi Paper Mills Limited	P220AG (normal type paper) AF P235 (*1 high image stability paper)
Ricoh Co., Ltd.	130LSB (*1 medium image stability paper)

*1 When using the AFP235 and 130LSB paper rolls, set the Print density on maximum in the Print Density Adjustment as described in Section 6-3.

Many paper types are available. Please use paper that meets the following criteria.

- | | |
|--------------------|---|
| 1. Paper type | General high-sensitivity thermal paper
General high-sensitivity label paper |
| 2. Paper width | 60 mm ~ 82-1 mm <ul style="list-style-type: none">• When using narrow paper, be sure that the paper is at least wide enough to keep the platen and head from touching. Never use paper that allows the head to touch the platen.• If the paper width is 70 mm or less, do not run the platen in reverse. |
| 3. Paper thickness | General thermal paper: 60 ~ 150 μ m
Label paper: Max. 160 μ m |
| 4. Paper rolls | Internal diameter: 25.4 mm (1 inch)
Outer diameter: 115 mm |

Rolls must have the thermal side facing inwards. Never use tape or other adhesive to fasten the trailing end of the paper to the roller.

5. Print area

	length of a	Length of b
Line mode	3.5 mm	75 mm
Page mode	1 mm	80 mm

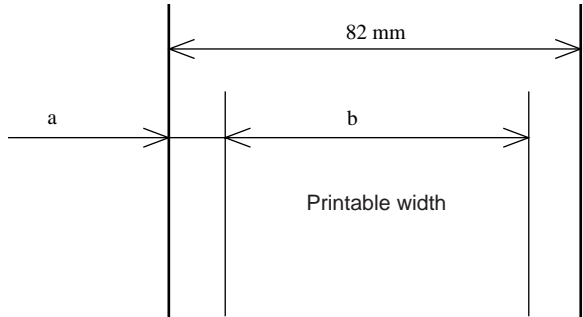

6. Black marking

Print density:
Print position:

1.2 or more

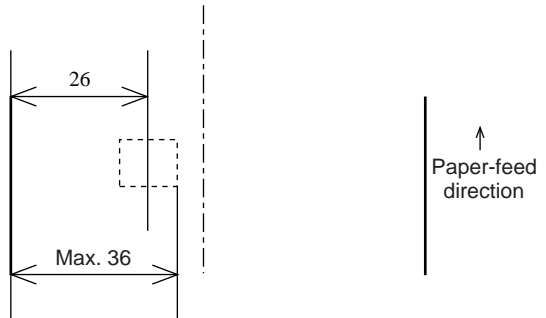

Marked side: Back (obverse of printable side)

Mark dimensions: Width 10 ~ 20 mm
(offset from center)
Length 3 ~ 10 mm

Positioning: Marks trailing end (relative to feed direction) identifies start position

PCS of Blackness: 0.9 or more

7. Label-paper specifications
- | | |
|-------------------------|--------------------------------|
| Label pitch: | Ⓐ 10~300 mm |
| Spacing between labels: | Ⓑ 3~10 mm (5 mm is preferred.) |
| Backing paper: | Ⓒ Max. 5 mm |

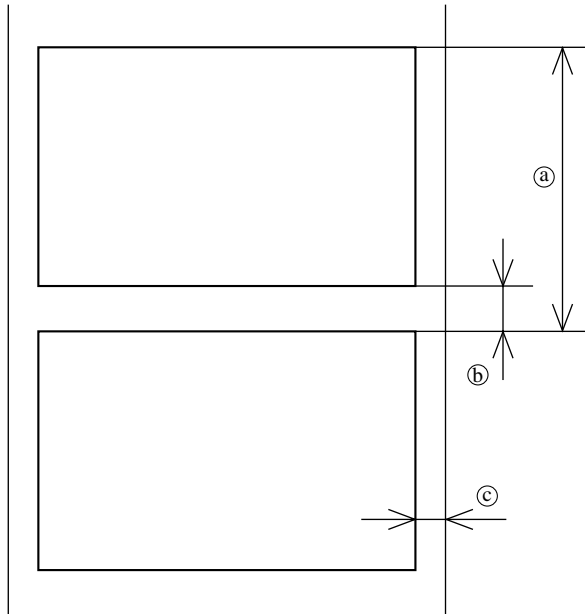

Appendix B: Dip switch setting

DIP switches are located on the interface board. The number of switches varies according to the board, as follows.

Parallel interface One 4-bit DIP switch

Serial interface One 10-bit DIP switch and one 4-bit DIP switch

The following is the procedure for changing the settings on DIP switches.

1. Make sure the printer is turned off.
2. Remove the screw from the ROM cover. Next take off the ROM cover, as shown in the illustration below.

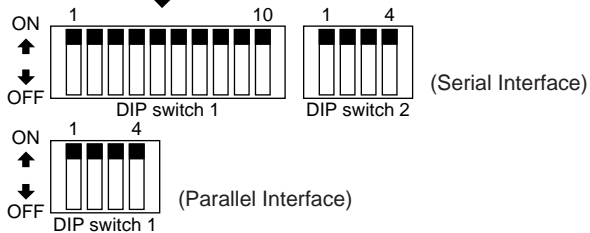
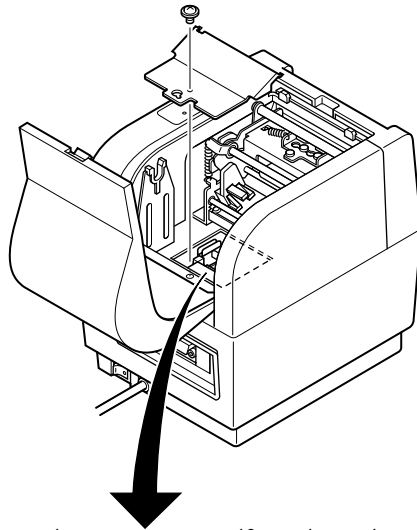

3. Set the switches using a pointed tool, such as a pen or flat-blade screwdriver.
4. Replace the ROM cover. Then secure it with the screw.
The new settings take effect when you turn on the printer.

B-1. Serial Interface

a) DIP switch #1

Switch	Setting	ON	OFF
1-1	Baud		
1-2	Baud		
1-3	Handshaking	DTR	X-ON/X-OFF
1-4	Data bits	8 bits	7 bits
1-5	Parity type	Not used	Used
1-6	Parity type	Odd	Even
1-7	DCI/DC3	Invalid	Valid
1-8	When turning power ON DC1/DC3 validmode	Select	Deselect
1-9	Not used		
1-10	Not used		

Baud	1-1	1-2
2400BPS	OFF	OFF
4800BPS	OFF	ON
9600BPS	ON	ON
19200BPS	ON	OFF

Factory settings : ALL ON

b) DIP switch #2

Switch	Setting	ON	OFF
2-1	Automatic Status Back function	Invalid	Valid
2-2	Not used		
2-3	Not used		
2-4	Not used		

Factory settings : ALL ON

B-2. Parallel Interface

Switch	Setting	ON	OFF
1-1	Automatic Status Back function	Invalid	Valid
1-2	Should not be changed (Should be set to on)		
1-3	Not used		
1-4	Not used		

Factory settings : ALL ON

Appendix C: Serial interface

C-1. Connectors and Signal Names (Serial Interface)

Pin No.	Signal name	Direction	Function
1	F-GND	–	Frame ground
2	TXD	OUT	Outgoing data
3	RXD	IN	Incoming data
4	RTS	OUT	Request To Send: The printer sets this signal on “SPACE” when it is ready to send.
5	CTS	IN	The host sets this signal on “SPACE” when it is ready to send. NOTE: The printer does not monitor this signal.
6	N/C		Not used
7	S-GND	–	Signal ground
8 ~ 10	N/C		Not used
11	RCH	OUT	The printer sets this signal on “SPACE” when it is ready to receive. This pin outputs the same signal as pin 20, to which it is connected.
12	N/C		Not used
13	S-GND	–	Signal ground.
14	FAULT	OUT	The printer sets this signal on “MARK” to indicate an error condition (machine error, no paper, etc.).
15 ~ 19	N/C		Not used
20	DTR	OUT	Data Terminal Ready: The printer sets this signal on “SPACE” when it is ready to receive. (1) DTR/DSR mode Space when receives enable. (2) X-On/X-Off mode Always space except during following states • Period between reset and communication enable • During self printing
21 ~ 25	N/C		Not used

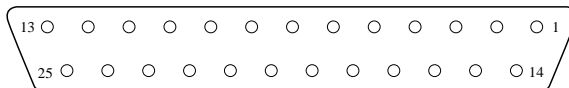

C-2. Interface Connections

Refer to the host computer's interface specifications for details of how to connect the interface. The following illustrations show typical connection configurations.

[RS-232C]

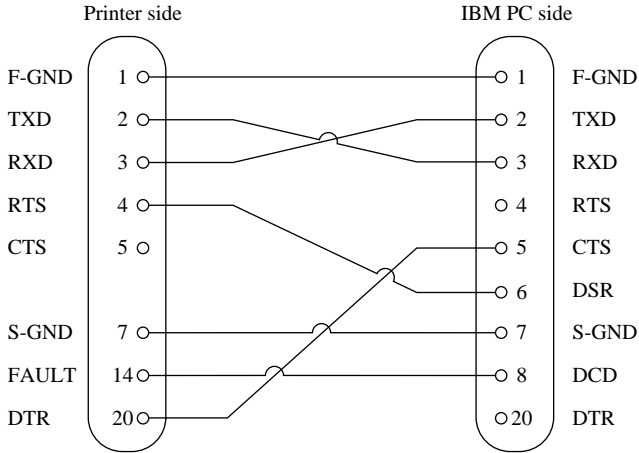

Appendix D: Parallel interface

The two-way parallel interface is compatible with the IEEE1284 compatibility mode, nibble mode and byte mode. Refer to the separate programmer's manual for details.

D-1. Table of Connection Signals for Each Mode

Pin No.	Direction	Compatibility Mode Signal Name	Nibble Mode Signal Name	Byte Mode Sginal Name
1	In	nStrobe	HostClk	HostClk
2	In/Out	Data0	Data0	Data0
3	In/Out	Data1	Data1	Data1
4	In/Out	Data2	Data2	Data2
5	In/Out	Data3	Data3	Data3
6	In/Out	Data4	Data4	Data4
7	In/Out	Data5	Data5	Data5
8	In/Out	Data6	Data6	Data6
9	In/Out	Data7	Data7	Data7
10	Out	nAck	PtrClk	PtrClk
11	Out	Busy	PtrBusy/Data3,7	PtrBusy
12	Out	PError	AckDataReq/Data2,6	AckDataReq
13	Out	Select	Xflag/Data1,5	Xflag
14	In	Not used	HostBusy	HostBusy
15		N/C	—	—
16		Single GND	Single GND	Single GND
17		Flame GND	Flame GND	Flame GND
18	OUT	Logic High (+5V)	Logic High (+5V)	Logic High (+5V)
19 ~ 30		Twisted pair return GND	Twisted pair return GND	Twisted pair return GND
31	In	nInit	nInit	nInit
32	Out	nFault	nDataAvail/Data0,4	nDataAvail
33		External GND	—	—
34	Out	Compulsion Status	—	—
35		N/C	—	—
36	In	nSelectIn	1284Active	1284Active

- NOTE:**
1. The prefix “n” on the signal name refers to low active signals. If the host does not have one of the signal lines listed above, two-way communications fails.
 2. For interfacing, signal lines should always use twisted pair cables with the return sides connected to the signal ground level.

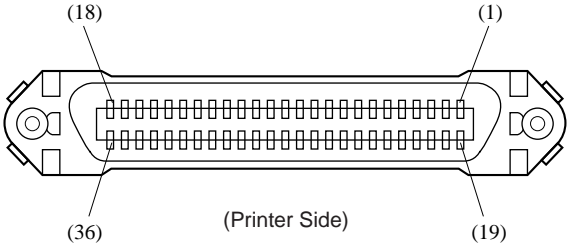

Compatible with Amphenol connector 57-30360

Appendix E: Peripheral unit drive circuit

A drive circuit for driving peripheral units (such as cash drawers) is featured on the main logic board of this printer. A modular connector for driving peripheral units is featured on the output side on the drive circuit. When using this circuit, connect the cable for the peripheral unit. (Cables must be prepared by the user.) Note that Page Mode does not support external-device drive commands. Drive commands are available only in Line Mode.

Use cables which meet the following specifications.

1. Use the modular plug as shown in the figure.
2. A separate ground wire is required for Europe only.
3. If the printer is to be used in Europe, the Ferrite core and the cable should be separate, as shown in the figure.

CAUTION: DO NOT connect any other plug to the peripheral unit connector.

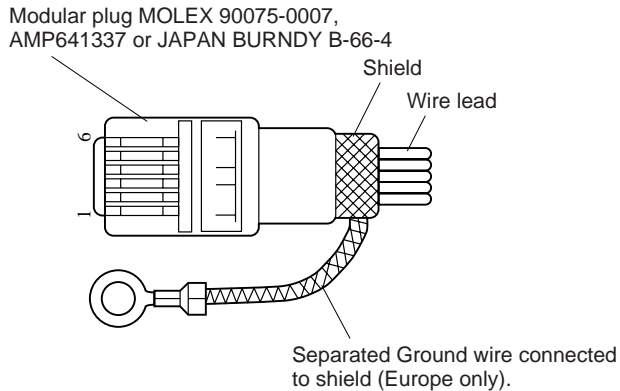

Cable specifications for peripheral unit.

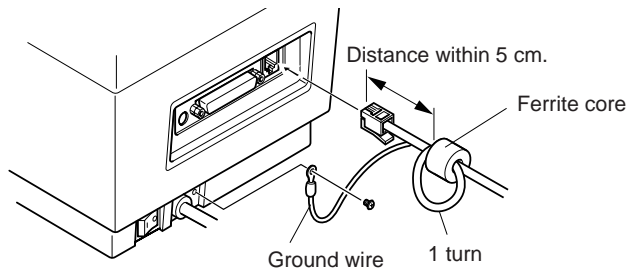

A separate ground wire and noise filter are required for Europe.

■ Drive circuit

The recommended drive circuit is shown below.

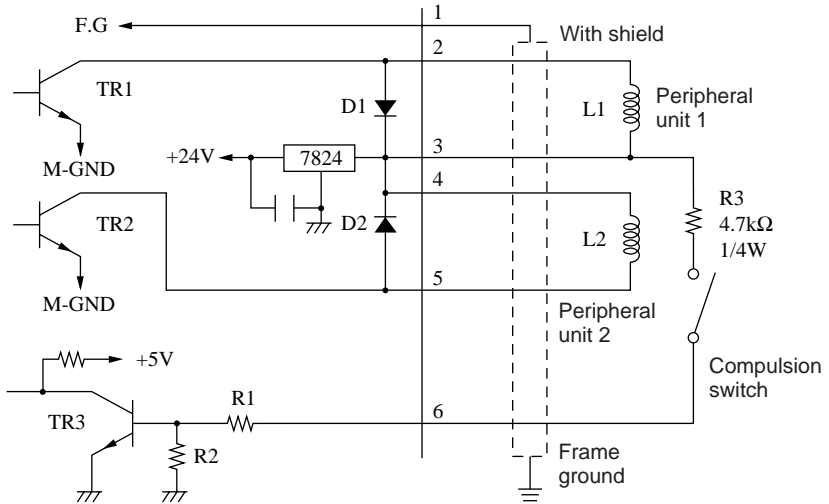

NOTES:

- Peripheral units #1 and #2 cannot be driven simultaneously.
When driving a device continuously, do not use it with the drive duty above 20%.
- The compulsion switch status is available as status data.
- Resistance for coils L1 and L2 is not less than 24 ohms.
- Absolute maximum ratings for diodes D1 and D2 (at $T_a=25\text{ }^\circ\text{C}$):
Average rectified current $I_o = 1\text{ A}$
Maximum forward surge current (60Hz, 1-cycle sine wave) $I_{FMS}=40\text{ A}$
- Absolute maximum rating for transistors TR1 and TR2 (at $T_a = 25\text{ }^\circ\text{C}$):
Collector current $I_c = 2\text{ A}$

Appendix F: Memory Switch Settings

Each memory switch is a 16-bit word stored in EEPROM. For details on the functions and settings of memory switches, see the separate Programmer's Manual.

The table below shows the factory settings for the memory switches.

Memory Switch	Hexadecimal Code	
	TSP412Z	TSP442Z
0	0000	0000
1	0000	0000
2	0000	0100
3	0000	0000



**SPECIAL PRODUCTS DIVISION
STAR MICRONICS CO., LTD.**

536 Nanatsushinya, Shimizu-ku, Shizuoka,
424-0066 Japan

Tel: (int+81)-54-347-0112

Fax: (int+81)-54-347-0409

Please access the following URL

<http://www.star-m.jp/eng/dl/dl02.htm>

for the latest revision of the manual.

**OVERSEAS SUBSIDIARY COMPANIES
STAR MICRONICS AMERICA, INC.**

1150 King Georges Post Road, Edison, NJ 08837-3729 U.S.A.
Tel: (int+1)-732-623-5500, Fax: (int+1)-732-623-5590

STAR MICRONICS EUROPE LTD.

Star House, Peregrine Business Park, Gomm Road,
High Wycombe, Bucks, HP13 7DL, U.K.

Tel: (int+44)-1494-471111, Fax: (int+44)-1494-473333

STAR MICRONICS ASIA LTD.

Rm. 1901-5, 19/F., Enterprise Square Two,
3 Sheung Yuet Road, Kowloon Bay, Hong Kong

Tel : (int+852)-2796-2727, Fax : (int+852)-2799-9344